



# **GENERAL EQUIPMENT CATALOG**

**2021**

**SPECIALISTS** IN LIQUID  
**HANDLING PRODUCTS**

**EST. 1983**

## **PROUDLY SERVING:**

- **AGRICULTURE**
- **ROADSIDE**
- **NURSERY**
- **LAWN & TREE**
- **GOLF & TURF**
- **CITRUS**
- **DEICING**
- **INDUSTRIAL**
- **AND MORE...**



# ABOUT CCI

Founded in 1983, CCI has been providing services for over 35 years here in Lake Wales, Florida. We specialize in liquid handling products for a wide variety of industries including agriculture, lawn care, roadside, and more. We have over 64,000 square feet of manufacturing & warehouse space with 16 acres of facilities and bulk tank inventory. This allows us to fill your order and ship the same day.



- Custom CAD design for spray equipment and liquid handling systems.
- Specialty welding of stainless steel, aluminum, and polyethylene.
- Complete service, repairs, & maintenance.
- You want it, we've got it! With over 15,000 stock items, your order is ready to ship today.
- Emergency same day delivery available.
- Mobile sales people provide you with on-site service for your company's needs.



**SPECIALISTS** IN LIQUID  
**HANDLING PRODUCTS**  
**EST. 1983**

# **TABLE OF CONTENTS**

<b>Pumps</b>	
Flo-Jet.....	1
Shur-Flo.....	1
Hypro.....	2
Udor.....	3
Misc. Pumps and Engines.....	3
<b>Regulators and Agitation Nozzles</b>	
Regulators.....	4
Agitation Nozzles .....	4
Accumulator.....	4
Pressure Gauges .....	4
<b>Spray Guns</b>	
Spray Guns and Wands .....	5
<b>Strainers - Hose - Reels</b>	
Strainers.....	6
Hose.....	6
Reels .....	6
Quick Couplers .....	6
<b>Tanks</b>	
Tanks Poly .....	7-9
Tanks Specialty.....	10-12
Tank Bases and Bands.....	13
Tank Valves .....	14
<b>Fittings</b>	
Stainless Steel.....	15-16
Banjo.....	17-20
<b>Chemical Handling Equipment</b>	
Chem-Pumps/Meters .....	21
Chemical Mix/Load Golf.....	22
Fill Systems .....	23
Fill Systems Pre-Mix Transfer .....	24
Environmental Systems .....	25
<b>Sprayers</b>	
Skid Mounted Sprayers.....	26-27
Custom Spray.....	28
<b>Special and Custom Equipment</b>	
De-Ice Equipment .....	29-30
Rears Sprayers and Eye Systems.....	31-32
Commercial Spray Rigs - Lawn & Tree, Herbicide & Rail Sprayers.....	33-35
Custom Agriculture Equipment.....	36
Spray Tips and Parts .....	37-40



**Flo-Jet Pumps**



Model: 04300-501A  
 • Max: 45 PSI • Voltage: 115V AC  
 • Max: 3.8 GPM • Type: Pressure Switch  
 • Ports: 1/2" HB • Viton/Valve, Santo Diaph.

CCI Part #  
P1495



Model: 02100-122A  
 • Max: 60 PSI • Voltage: 12V DC  
 • Max: 2.2 GPM • Type: Pressure Switch  
 • Ports: 3/8" FPT • Viton/Valve, Viton Diaph.

CCI Part #  
P1500



Model: 02100-032A  
 • Max: 60 PSI • Voltage: 115V AC  
 • Max: 1.6 GPM • Type: Pressure Switch  
 • Ports: 3/8" FPT • Santo/Valve, Santo Diaph.

CCI Part #  
P1501



Model: 02100-959A  
 • Max: 70 PSI • Voltage: 12V DC  
 • Max: 1.8 GPM • Type: Internal By-Pass  
 • Ports: 3/8" FPT • Viton/Valve, Santo Diaph.

CCI Part #  
P1511



Model: 02130-132A  
 • Max: 95 PSI • Voltage: 12V DC  
 • Max: 1.8 GPM • Type: Pressure Switch  
 • Ports: 1/4" FPT • Viton/Valve, EPDM Diaph.

CCI Part #  
P1498



Model: 04300-500A  
 • Max: 45 PSI • Voltage: 12V DC  
 • Max: 3.7 GPM • Type: Pressure Switch  
 • Ports: 1/2" Barb • Viton/Valve, Santo Diaph.

CCI Part #  
P1499



Model: R8600134  
 • Max: 70 PSI • Voltage: 12V DC  
 • Max: 6.0 GPM • Type: Pressure Switch  
 • Ports: 3/4" HB • EPDM or Viton/Valve, Santo Diaph.

CCI Part #  
P1375



Model: 04300-504  
 • Max: 45 PSI • Voltage: 12V DC  
 • Max: 4.9 GPM • Type: Pressure Switch  
 • Ports: 3/4" HB • Viton/Valve, Santo Diaph.

CCI Part #  
P1502

**Shur-Flo Pumps**



Model: 8000-543-236  
 • Max: 50 PSI • Voltage: 12V DC  
 • Max: 1.8 GPM • Type: Pressure Switch  
 • Ports: 3/8" FPT • Viton/Valve, Santo Diaph.

CCI Part #  
P1600



Model: 8000-533-236  
 • Max: 60 PSI • Voltage: 115V AC  
 • Max: 1.4 GPM • Type: Internal By-Pass  
 • Ports: 3/8" FPT • Viton/Valve, Santo Diaph.

CCI Part #  
P1600A



Model: 8007-543-836  
 • Max: 50 PSI • Voltage: 12V DC  
 • Max: 1.8 GPM • Type: Toggle Switch & PS  
 • Ports: 3/8" FPT • Viton/Valve, Santo Diaph.

CCI Part #  
P1625A



Model: 8030-813-239  
 • Max: 150 PSI • Voltage: 12V DC  
 • Max: 1.6 GPM • Type: Pressure Switch  
 • Ports: 3/8" FPT • Viton/Valve, Santo Diaph.

CCI Part #  
P1625



Model: 2088-343-135  
 • Max: 45 PSI • Voltage: 12V DC  
 • Max: 3.0 GPM • Type: Pressure Switch  
 • Ports: 1/2" MPT • Viton/Valve, Santo Diaph.

CCI Part #  
P1601



Model: 2088-414-534  
 • Max: 45 PSI • Voltage: 12V DC  
 • Max: 3.0 GPM • Type: Pressure Switch  
 • Ports: 1/2" MPT • Viton/Valve, Santo Diaph.

CCI Part #  
P1601B



Model: 8000-541-236  
 • Max: 60 PSI • Voltage: 12V DC  
 • Max: 1.0 GPM • Type: Pressure Switch  
 • Ports: 3/8" FPT • Viton/Valve, Santo Diaph.

CCI Part #  
P1599



Model: 8000-543-238  
 • Max: 100 PSI • Voltage: 12V DC  
 • Max: 1.47 GPM • Type: Pressure Switch  
 • Ports: 3/8" FPT • Viton/Valve, Santo Diaph.

CCI Part #  
P1627

**Hydro Centrifugal Pumps**



Model: H9202C  
H9203C  
Type: Cast Iron  
Cast Iron  
Specifications:  
• Max Flow: 136 GPM  
• Max: 180 PSI  
• Max: 6000 RPM  
• Shaft: 5/8"



Model: H9203PS  
Type: Poly Pump  
Specifications:  
• Max Flow: 92 GPM  
• Max: 80 PSI  
• Max: 4200 RPM  
• Shaft: 7/8" Stainless



Model: H9203C-SP  
Type: Cast Iron  
Self-Priming  
Specifications:  
• Max Flow: 120 GPM  
• Max: 157 PSI  
• Max: 5500 RPM  
• Shaft: 5/8"



Model: H9700B  
Type: Bronze  
12 Volt  
Specifications:  
• Max Flow: 19 GPM  
• Max: 7 PSI  
• Max: 5.5 AMPS  
• Ports: 3/4" FPT



Model: H9006C-O  
H9008C-O  
H9016C-O  
H9018C-O  
Type: Cast Iron  
Gear Driven  
Specifications:  
• Max Flow: 117GPM  
• Max: 78 PSI  
• Max: 600 RPM  
• Shaft: 1 3/8"



Model: H9303C  
HM1C-5C  
Type: Cast & SS  
Hydraulic Driven  
Specifications:  
• Max Flow: 114 GPM  
• Max: 130 PSI

**Hydro Roller Pumps**



Model: H4101C  
H4101N  
H4101XL  
Type: Cast Iron  
Ni-Resist  
Silver series  
Specifications:  
• Max Flow: 7GPM  
• Max: 150 PSI  
• Max: 2600 RPM  
• Ports: 3/4" FPT  
• Shaft Size: 5/8"



Model: H6500C  
H6500N  
H6500XL  
Type: Cast Iron  
Ni-Resist  
Silver series  
Specifications:  
• Max Flow: 9.7 GPM  
• Max: 300 PSI  
• Max: 1200 RPM  
• Ports: 3/4" FPT  
• Shaft Size: 5/8"



Model: H7560C  
H7560N  
H7560XL  
Type: Cast Iron  
Ni-Resist  
Silver series  
Specifications:  
• Max Flow: 22.5 GPM  
• Max: 300 PSI  
• Max: 1000 RPM  
• Ports: 3/4" FPT  
• Shaft Size: 15/16"



Model: H7700C  
H7700N  
H7700XL  
Type: Cast Iron  
Ni-Resist  
Silver series  
Specifications:  
• Max Flow: 22.1GPM  
• Max: 300 PSI  
• Max: 1000 RPM  
• Ports: 3/4" FPT  
• Shaft Size: 15/16"

**Hydro Diaphragm Pumps**



Model: H9910-D252  
H9910-D252GRGI  
Specifications:  
• Max Flow: 6 GPM  
• Max: 290 PSI  
• Max: 3600 RPM  
• 3/4" Inlet, 1/2" Outlet



Model: H9910-D30  
H9910-D30GRGI  
H9910-D30AP-A  
Specifications:  
• Max Flow: 9.5 GPM  
• Max: 580 PSI  
• Max: 3600 RPM  
• 1" Inlet, 1/2" Outlet



Model: H9910-D50  
H9910-D50AP-A  
Specifications:  
• Max Flow: 14 GPM  
• Max: 580 PSI  
• Max: 550 RPM  
• 1-1/4" Inlet, 1/2" Out



Model: H9910-D423  
H9910-D423GRGI  
H9910-D423AP-A  
Specifications:  
• Max Flow: 11 GPM  
• Max: 290 PSI  
• Max: 650 RPM

**Proportional Injection Systems**

Acid Systems

- pH Adjustment
- Iron Stain Removal
- Bacteria reduction & Oxidation

Fert. Systems

- Turf Feeding
- Promotes Growth
- Less Cost/Water/Labor

- CHEM-PRO® Pumps
- .40 - 40 GPH
- 150 PSI Max
- LCD Display
- F2000 Paddle Wheel Flow Meter
- pH Adjustment
- Iron Stain Removal
- Bacteria Reduction & Oxidation





## Udor Diaphragm Pumps



Model:  
UKAPPA1812Volt

- Specifications:
- Max Flow: 4 GPM
  - Max: 70 PSI
  - Voltage: 12V DC
  - 3/4" Inlet, 1/2" Outlet



Model:  
UIOTA20

- Specifications:
- Max Flow: 4.5 GPM
  - Max: 275 PSI
  - Max: 540 RPM
  - 3/4" Inlet, 3/8" Outlet



Model:  
UIOTA17M Electric

- Specifications:
- Max Flow: 4.5 GPM
  - Max: 200 PSI
  - Voltage: 115V AC
  - 3/4" Inlet, 3/8" Outlet



Model:  
UKAPPA40  
UKAPPA40GR

- Specifications:
- Max Flow: 10.5 GPM
  - Max: 560 PSI
  - Max: 540 RPM
  - 1" Inlet, 1/2" Outlets



Model:  
UKAPPA55  
UKAPPA55GR5  
UKAPPA55GR8

- Specifications:
- Max Flow: 15 GPM
  - Max: 350/560 PSI
  - Max: 540 RPM
  - 1-1/4" Inlet, 1/2" Outlets



Model:  
UKAPPA75  
UKAPPA75GR

- Specifications:
- Max Flow: 20 GPM
  - Max: 560 PSI
  - Max: 540 RPM
  - 1.25" Inlet, 3/4" Outlet



Model:  
UKAPPA100  
UKAPPA100C  
UKAPPA100GR

- Specifications:
- Max Flow: 26GPM
  - Max: 560 PSI
  - Max: 540 RPM
  - 1-1/2" Inlet, 1/2" Outlets



Model:  
UKAPPA120/TS  
UKAPPA120/CC  
UKAPPA120/GR

- Specifications:
- Max Flow: 35 GPM
  - Max: 700 PSI
  - Max: 540 RPM
  - 1.50" Inlet, 3/4" Outlet



Model:  
URO110  
URO110C  
URO110GR-5  
URO110GR

- Specifications:
- Max Flow: 29GPM
  - Max: 300 PSI
  - Max: 540 RPM
  - 1-1/4" Inlet, 3/4" Outlets



Model:  
UBETA150CC

- Specifications:
- Max Flow: 42 GPM
  - Max: 700 PSI
  - Max: 540 RPM
  - 1.50" Inlet, 3/4" Outlet

## Additional Pumps/Engines/Gear Box



Model:  
B205PB-V  
B200PB-I  
B200PB-SS

### Banjo Transfer Pumps

- Description:
- 2" Poly Pump
  - 2" Cast Iron Pedestal Pump
  - 2" SS Pedestal Pump



Model:  
B200PH-5  
B200PH-5E

**Banjo 2" Pumps w/Gas Engine**

Description:

- 2" Poly Pump
- Electric Start option



Model:  
GE-85-LE  
GESC-85-LE

### ACE Poly Pumps w/ Gas Engine

- Description:
- 1" Poly Pump
  - 1" Silicon Carbide Seal
  - 2" SS Pedestal Pump



Model: Description:  
E110 GX160 Standard w/Oil Alert  
E115 GX160 6:1 Gear Reduction  
E120 GX240 Standard w/Oil Alert  
E141A GX390 Standard w/Oil Alert

### Honda Engines



Model:  
H9910KIT1640  
D30 Gear Box  
H9910KIT1642  
D50 Gear Box

- Specifications:
- 6:1 Gear Reduction
  - Fits: 3/4" Shaft Engine
  - 6:1 Gear Reduction
  - Fits: 1" Shaft Engine



Model: Description:  
E116 GX160 Standard w/Oil Alert  
E125 GX240 Standard w/Oil Alert  
E141 GX390 Standard w/Oil Alert

### Honda Engines w/Electric Start



**Model:** H9910KIT1990  
**Specifications:**

- Fits: D252 Diaph. Pump
- Max: 275 PSI
- Max: 6 GPM
- 5/8" Bypass, 3/8" Outlet



**Model:** H9910-GS40GI  
**Specifications:**

- Fits: D30/D50 Pumps
- Max: 550 PSI
- Max: 15 GPM
- 5/8" Bypass, 1/2" Outlet



**Model:** U6010.23  
**Specifications:**

- Fits: IOTA17 Pump
- Max: 275 PSI
- Max: 5 GPM
- 3/8" Bypass Port



**Model:** U6010.24  
**Specifications:**

- Fits: Kappa40,55 Pumps
- Max: 560 PSI
- Max: 20 GPM
- 3/4" Bypass, 1/2" Outlet



**Model:** U6047.06  
**Specifications:**

- Fits: Kappa75 Pump
- Max: 560 PSI
- Max: 26 GPM
- 3/4" Bypass, 1/2" Outlet



**Model:** U6005.31  
**Specifications:**

- Fits: Gamma62 Pump
- Max: 600 PSI
- Max: 26 GPM
- 3/4" BSP Inlet, 3/4" Bypass



**Model:** UD1/4.50  
UD1/4.150  
**Specifications:**

- Fits: Kappa18/12V
- Max: 50/150 PSI
- Max: 4.5 GPM
- 1/4" Inlet, 1/4" Bypass



**Model:** U6005.15  
**Specifications:**

- Fits: Universal Application
- Max: 1000 PSI
- Max: 45 GPM
- 3/4" Inlet, 1" Bypass



**Model:** S8460-3/4  
**Specifications:**

- Max: 70 GPM
- Max: 300 PSI
- 3/4" Inlet, 3/4" Out
- 1/4" Gauge Port



**Model:** S6815-3/4-300  
S6815-3/4-700  
**Specifications:**

- Max: 65 GPM
- Max: 300/700 PSI
- 3/4" Inlet, 3/4" Outlet
- Brass Body



**Model:** S23120A-1/2-PP  
S23120A-3/4-PP  
**Specifications:**

- Fits: Universal Application
- Max: 150 PSI
- Max: 30 GPM
- 1/4" Gauge Port



**Model:** S12690-3/4-NYB  
**Specifications:**

- Throttling Valve
- Max: 125 PSI
- Max: 56 / 82 GPM
- 1/2", 3/4" Connections

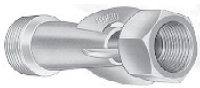

**Model:** H3371  
H3371-0019  
**Specifications:**

- 1/2" FPT Inlet Jet Orifice
- 3/4" MPT Inlet Orifice
- Nylon Body and Orifice
- Jet Agitator

### Hypro Jet Agitators



**Model:** H3371-0028  
**Specifications:**

- 3/4" MPT Inlet Jet Orifice
- High Volume Jet Agitator
- 3 Orifices to match flow
- Glass-filled Polypropylene

### Hypro HV Jet Agitator



**Model:** H3375-0003  
**Specifications:**

- Surge Tank – Dampener
- Max: 500 PSI
- Max: 10 GPM
- 1/2" MPT Connection

### Hypro Accumulator Tank



**Model:** M201 0-100 PSI  
M202 0-200 PSI  
M203 0-300 PSI  
M204 0-600 PSI  
**Specifications:**

- 2-1/2" Liquid Filled Gauge
- Stainless Case
- Brass Internal Parts & Stem
- 1/4" NPT Stem

### Pressure Gauges



**Spray Guns**

Model:  
S22670PP15406



Specifications:  
• Max: 150 PSI  
• Adjustable Spray Tip  
• Lightweight Polypro  
• 15" Extension, 3/8 Inlet

Model:  
U4.802.14WB



Specifications:  
• Max: 300 PSI  
• 20" Stainless Wand  
• Adjustable Spray Tip  
• Poly Trigger Valve

Model:  
SAA31



Specifications:  
• Max: 500 PSI  
• Max: 3 GPM  
• Forged Brass Body  
• 1/4" MPT Inlet

Model:  
S4688



Specifications:  
• Max: 250 PSI  
• Max: 2 GPM  
• Forged Brass Body  
• 1/4" FPT Inlet, 11/16 Outlet

Model:  
S4754



Specifications:  
• Brass Handle Extension  
• 1/4" MPT x 3/4" FGHT  
• Strainer Handle 50 M  
• 1/4" FPT Inlet

Model: Straight Ext.



S7715-8

Model: Curved Ext.

S7715-18

S7715-24

S7715-36

8"

18"

24"

36"

S6671-8

S6671-18

S6671-24

S6671-36

8"

18"

24"

36"

Model:  
AA30L-22425-18  
AA30L-22425-24  
AA30L-22425-36  
AA30L-22425-48



Specifications:  
• Max: 250 PSI  
• Max: 5 GPM  
• Brass Wand, Nylon Grip  
• 1/4" FPT Inlet

Model:  
SAA43H-6



Specifications:  
• Max: 800 PSI  
• Max: 14 GPM  
• Brass / Aluminum Const.  
• 1/2" Inlet

Model:  
S25660-0



Specifications:  
• Max: 200 PSI  
• Max: 6 GPM  
• Nylon w/Viton O-Rings  
• 3/4" FPT Inlet

Model:  
SAA2-60



Specifications:  
• Max: 800 PSI  
• Max: 10 GPM  
• Brass Body  
• 3/4" FHT Inlet

Model:  
U26.901.162



Specifications:  
• Max: 850 PSI  
• Max: 15 GPM  
• Adjustable Spray Pattern  
• 1/2" HB Inlet

Model:  
U35.901.16



Specifications:  
• Max: 600 PSI  
• Max: 5 GPM  
• 7" Barrel Extension  
• 1/2" HB Inlet

Model:  
U23.208.84



Specifications:  
• Max: 700 PSI  
• Max: 18 GPM  
• Nickel Plated Aluminum  
• 1/2" FPT Inlet

Model:  
U7.901.103



Specifications:  
• Max: 850 PSI  
• Max: 25 GPM  
• 17" Barrel, Adj. Pattern  
• 1/2" HB Inlet

Model:  
GGJD9C-B



Specifications:  
• Max: 550 PSI  
• Max: 10 GPM  
• Quick Adj. Spray Pattern  
• 3/4" FPT Inlet

Model:  
CCILAWNGUN



Specifications:  
• 36" Aluminum Spray Wand  
• 1/2" Quick Coupler  
• 1/2" Brass Ball Valve  
• Flat Fan Lawn Spray Tip



## Filter / Strainers



### Hypro Strainers

Model:	Size:	Model:	Size:
H3350-0082	1/4"	H3350-0075	1-1/4"
H3350-0042	1/2"	H3350-0113	1-1/2"
H3350-0044	3/4"	H3350-0061	1"



### Spraying Systems Strainers

Model:	Size:
SAA124A34PP50	3/4" FPT
SAA124A1PP50	1" FPT
SAA12411/4NY50	1-1/4" FPT
SAA12411/2NYB50	1-1/2" FPT



### Polypropylene Clear Bowl Strainers

Model:	Size:
HLSFP012VS2CC	1/2" FPT Strainer
HLSFP034VS2CC	3/4" FPT Strainer
HLSFP100VS2CC	1" FPT Strainer
HLSFP112VS4C	1-1/2" FPT Strainer



### Banjo Y-Strainers

Model:	Size:
BLS10040	1" Strainer / 40 Mesh
BLS15050	1-1/2" Strainer / 50 Mesh
BLS20050	2" Strainer / 50 Mesh
BLS30020	3" Strainer / 20 Mesh

## Spray Hose



### PVC Clear Braided Hose

Model:	Size:	Model:	Size:
HZ929	1/4" ID	HZ933	3/4"
HZ930	3/8" ID	HZ934	1"
HZ931	1/2" ID	HZ934A	1-1/4"
HZ932	5/8" ID		



### High Pressure PVC Spray Hose (600 PSI)

Model:	Size:	
HZ900	3/8" ID	• 300' Per Roll
HZ901	1/2" ID	
HZ903	3/4" ID	



### Red Rubber Spray Hose (200 PSI)

Model:	Size:
HZ904	3/8" ID
HZ905	1/2" ID
HZ905A	3/4" ID
HZ906	1" ID



### PVC Suction Hose

Model:	Size:	Model:	Size:
HZ910	3/4" ID	HZ914	2" ID
HZ911	1" ID	HZ915	3" ID
HZ912	1-1/4" ID	HZ916	4" ID
HZ913	1-1/2" ID		

## Hose Reels



### Hannay Hose Reels

Model:	Description:
HZ968	10" (1/2" Hose x 100' Capacity)
HZ974	12" (1/2" Hose x 150' Capacity)
HZ975	18" (1/2" Hose x 300' Capacity)
HZ976	18" (1/2" Hose x 300' Capacity) Elect.



### Titan Hose Reels

Model:	Description:
HZ4312	12" Aluminum/SS Hose Reel
HZ4318	18" Aluminum/SS Hose Reel
HZ5512	12" All Stainless Steel Reel
HZ5518	18" All Stainless Steel Reel



### Hose Reel Swivels

Model:	Description:
HZ973	1/2" 90° Brass Swivel
HZ8620	1/2" 90° Stainless Swivel



### Reusable Hose Repair End

Model:	Description:
FB600	3/8" MPT x 3/8" Hose
FB601	3/8" MPT x 1/2" Hose
FB603	1/2" MPT x 3/8" Hose
FB604	1/2" MPT x 1/2" Hose

## Quick Couplers



### Male Quick Coupler Plugs

Model:	Description:
FB430A	1/4" MPT Brass Plug
FB429	3/8" MPT Brass plug
FB433	1/2" MPT Brass Plug



### Female Quick Coupler Plugs

Model:	Description:
FB430	1/4" FPT Brass Plug
FB428	3/8" FPT Brass Plug
FB432	1/2" FPT Brass Plug
FB434	3/4" FPT Brass Plug



### Male Quick Coupler Socket

Model:	Description:
FB419	3/8" MPT Socket Brass
FB423	1/2" MPT Socket Brass



### Female Quick Coupler Socket

Model:	Description:
FB431	1/4" FPT Socket Brass
FB418	3/8" FPT Socket Brass
FB422	1/2" FPT Socket Brass
FB425	3/4" FPT Socket Brass



**Polyethylene Storage Tanks**

**Vertical Storage Tank**

- 100% Virgin Polyethylene
- FDA approved for potable water storage
- Molded-in gallon indicators on sides



Available in sizes up to 20,000 Gallons.

Model:	Gal.	Dia.	Height	Lid
T1007A	20	16"	28"	8"
T1008N	25	18"	29"	5"
T1009A	40	18"	43"	5"
T1010N	50	18"	53"	5"
T1012N	65	23"	43"	8"
T1014A	75	23"	50"	7"
T1016D	100	31"	37"	8"
T1018N	100	28"	43"	8"
T1020N	105	23"	63"	8"
T1024N	120	38"	31"	5"
T1026N	150	30"	56"	8"
T1028N	165	31"	56"	16"
T1030N	200	30"	72"	8"
T1032N	210	32"	67"	16"
T1040N	220	42"	44"	5"
T1046N	250	30"	89"	8"
T1048N	300	35"	79"	16"
T1052N	305	46"	50"	16"
T1056R	330	46"	51"	16"
T1058A	425	42"	75"	8"
T1060N	500	48"	73"	16"
T1060AA	505	46"	80"	16"
T1068N	550	67"	44"	16"
T1070A	625	64"	50"	8"
T1071D	650	56"	71"	16"
T1072N	750	48"	103"	16"
T1076N	850	48"	118"	16"
T1076A	850	54"	94"	16"
T1086A	900	46"	132"	16"
T1088N	1000	64"	80"	16"
T1096N	1100	87"	53"	16"
T1100A	1200	64"	97"	16"
T1100D	1200	76"	68"	16"
T1104N	1500	64"	116"	16"
T1108N	1550	87"	67"	16"
T1112R	1650	86"	78"	16"
T1116A	2000	91"	84"	16"
T1116AA	2000	64"	156"	16"
T1124N	2100	87"	89"	16"
T1125A	2150	102"	71"	16"
T1128N	2500	95"	91"	16"

**Vertical Storage Tanks Cont:**

Model:	Gal.	Dia.	Height	Lid
T1128A	2500	91"	103"	16"
T1132N	3000	95"	109"	16"
T1136N	4000	102"	125"	16"
T1136A	4000	96"	140"	16"
T1138N	4200	102"	131"	16"
T1140N	5000	102"	152"	16"
T1148N	6000	102"	182"	16"
T1152N	6100	119"	140"	16"
T1156N	6500	120"	149"	16"
T1156O	6502	102"	196"	16"
T1158N	7800	119"	176"	16"
T1159N	8400	120"	187"	16"
T1160N	9000	141"	146"	22"
T1164N	10000	141"	160"	22"
T1165N	11000	144"	167"	22"
T1168N	13000	144"	198"	22"
T1170N	15000	165"	186"	22"
T1170NW	15000	165"	186"	22"
T1175N	20000	165"	242"	16"

**Poly Cone Bottom Tanks**

- 100% Virgin Polyethylene
  - FDA approved for potable water storage
  - Molded in gallon indicators on sides
- Available up to 10,000 Gallons.  
\*Includes poly stand



Model:	Gal.	Dia.	Height	Lid
T2004N	15	19"	23"	8"
T2007A	30	24"	30"	12"
T2008N	35	23"	29"	8"
T2008A*	35	24"	49"	12"
T2009A	40	30"	34"	12"
T2015A	55	24"	42"	12"
T2015A*	60	24"	62"	12"
T2015N	60	31"	32"	16"
T2020O	80	32"	37"	10"
T2021A	85	30"	43"	12"
T2025A	110	30"	51"	12"
T2026R	110	32"	44"	15"
T2030A	150	36"	51"	12"
T2032N	175	42"	49"	16"
T2037A	200	42"	55"	12"
T2038R	220	44"	50"	6"
T2040D	250	47"	51"	16"
T2044N	300	48"	50"	16"
T2044A	300	42"	67"	16"
T2045N*	310	43"	72"	8"
T2048D	400	47"	72"	16"
T2052N	500	48"	85"	16"
T2062N	750	72"	56"	16"
T2067A	1000	64"	98"	16"
T2068N	1050	72"	75"	16"



Poly Cone Bottom Tanks Cont:

Model:	Gal.	Dia.	Height	Lid
T2070A	1490	64"	132"	16"
T2074N	1600	88"	84"	16"
T2074N*	1600	89"	96"	16"
T2080N	2500	96"	105"	16"
T2082N*	2500	99"	116"	16"
T2086N	3000	96"	123"	16"
T2089A	4900	102"	159"	16"
T2090N	5500	119"	148"	16"
T2092N	6000	102"	195"	16"
T2094N	7500	141"	148"	16"
T2100N	10000	141"	190"	16"

*See Page 13 for Stands*

## Horizontal Applicator Tanks



Model:	Gal.	Dia.	Length	Lid
T4020N	20	15"	31"	5"
T4028N	30	23"	21"	5"
T4032N	55	23"	34"	5"
T4036N	85	23"	52"	5"
T4040A	95	24"	56"	5"
T4044N	110	30"	41"	8"
T4048N	150	32"	46"	8"
T4056N	200	32"	62"	8"
T4060N	200	38"	47"	8"
T4072N	300	38"	68"	8"
T4076N	400	42"	74"	8"
T4080N	500	48"	75"	8"

*Ask about Saddles and Cradles*

## Slimline Space Saver Tanks



Model:	Gal.	Wid.	Len.	Ht.
T4052N	150	28"	50"	41"
T4064A	200	24"	55"	46"
T4068A	250	24"	61"	51"

*Ask about Saddles*

## Elliptical Leg Tanks



This elliptical leg tank style is designed to provide the greatest capacity with the lowest center of gravity, making it the best design for transporting larger volumes. Elliptical tanks feature mold-in legs that act as "baffles" to reduce sloshing and provide increased stability during transport.

Model:	Gal.	W.	L.	H.	Lid	Band
T3130N	335	48"	71"	33"	16"	2
T3140A	510	57"	80"	39"	16"	2
T3140N	535	57"	80"	39"	16"	2
T3144N	1035	79"	89"	54"	16"	3
T3152N	1635	71"	142"	58"	16"	4
T3156N	2035	84"	142"	56"	16"	4
T3160N	2635	90"	140"	72"	16"	4
T3164N	3135	88"	150"	80"	16"	4
T3168N	4035	92"	192"	75"	16"	4

*See Page 13 for Bands*

## Elliptical Tanks



Model:	Gal.	W.	L.	H.	Lid
T8008N	200	40"	66"	30"	8"
T8012N	300	48"	70"	36"	8"
T8016N	500	57"	82"	44"	16"
T8020N	750	69"	88"	48"	16"
T8024N	1000	78"	90"	55"	16"
T8025N	1600	78"	138"	54"	16"

*See Page 13 for Skids*

## Spot Sprayer Tanks

- Molded inserts for pump mounting & accessories.
- Molded in gallon indicators on side walls for easy calibration.

Model:	Gallons
T4016R	15
T4017A	15
T4024A	25
T4024R	25
T4029A	40
T4035A	60





## Horizontal Leg Tanks

Used primarily for transport and nursing applications, leg tanks feature molded-in legs that act as “baffles” to reduce sloshing.

*See Page 13 for Bands*

Model:	Gal.	Dia.	Length	Lid	Band
T3004N	35	20"	29"	5"	2
T3004A	35	18"	34"	5"	2
T3008N	65	23"	43"	5"	2
T3008A	65	24"	39"	5"	2
T3012N	125	32"	41"	8"	2
T3012A	125	32"	44"	8"	3
T3002A	165	32"	54"	8"	3
T3016N	225	38"	49"	8"	2
T3016A	225	38"	52"	8"	3
T3020N	325	38"	68"	16"	2
T3022A	335	44"	56"	16"	2
T3021N	425	49"	60"	16"	2
T3024N	525	49"	71"	16"	2
T3025A	535	48"	78"	16"	3
T3028N	725	49"	101"	16"	3
T3029A	735	48"	103"	16"	3
T3032N	1025	49"	139"	16"	4
T3033A	1065	56"	105"	16"	3
T3033N	1325	66"	99"	16"	4
T3036N	1625	63"	139"	16"	4
T3037N	5025	92"	190"	16"	5

## Pest Control Tanks



These tanks are rotationally molded polyethylene with a ribbed design for extra strength. The standard color is white-UV inhibitors are added for protection against sunlight (optional colors available in large quantities). They are ideal for agricultural, nursery, lawn care and commercial turf sprayers.

Model:	Gal.	Len.	Wid.	Height
T5520N	30	25"	19"	23"
T5530A	50	38"	19"	23"
T5540A	100	38"	30"	29"
T5550A	150	48"	37"	29"
T5560A	200	48"	37"	38"
T5570A	300	69"	37"	40"

## Poly Loaf Tanks

- Loaf tanks are molded non-corrosive polyethylene with one piece seamless construction
- FDA approved for potable water storage
- \* Tanks do not include lids or fittings.

Model:	Gal.	Len.	Wid.	Height
T5034R	6	18"	12"	8"
T5052R	12	23"	10"	14"
T5058R	13	20"	17"	9"
T5066R	14	24"	14"	10"
T5088R	15	23"	14"	12"
T5094R	16	27"	14"	10"
T5102R	20	22"	19"	11"
T5116R	20	26"	14"	13"
T5124R	21	27"	14"	13"
T5132R	21	36"	20"	7"
T5154R	29	30"	20"	12"
T5166R	31	30"	24"	10"
T5174R	30	43"	16"	11"
T5192R	50	36"	18"	18"
T5198R	61	35"	27"	15"
T5206R	60	69"	27"	9"

POLYETHYLENE LOAF TANKS

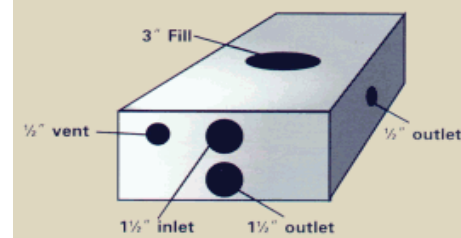

Fitting location examples.

Part # T9670CCS



275 Gallon UN Transparent Tanks (Reconditioned)  
6" Top Lid  
2" Bottom Valve  
Polyethylene Bottle  
Galvanized Steel Cage  
48"W x 40"L x 46"H  
Call for Pricing

Made from 100% virgin resin, these vertical polyethylene tanks have double walls for extra strength and durability when storing water or liquid chemicals. Seamless and water tight as a result of being rotationally molded. The food grade material used to make this tank is approved by the FDA as safe to hold potable water.

## Double Wall Storage Tanks

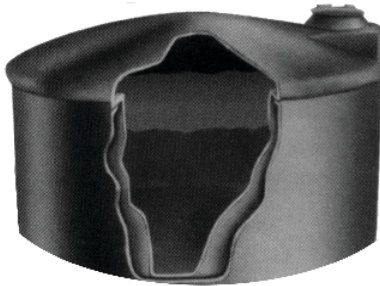

Model:	Gal.	Dia.	Height	Lid
T7016PDBL	105	36"	42"	5"
T7024PDBL	160	36"	59"	5"
T7030PDBL	540	77"	48"	17"
T7034PDBL	1000	77"	79"	17"
T7040PDBL	1550	96"	84"	17"
T7046PDBL	2500	96"	119"	17"
T7050PDBL	3150	122"	92"	24"
T7060PDBL	4400	122"	118"	24"
T7066PDBL	5400	143"	117"	24"
T7080PDBL	8700	143"	174"	24"

## Transport Tanks

This one-piece, molded polyethylene tank is designed for economy. The low profile, flat bottom, rectangular design saves space and does not need stands or cradles for support. The tank comes complete with an 8" anti-surge vented fill cap and molded-in calibrations.

Model:	Gal.	Len.	Wid.	Ht.	Lid
T5191A	45	37"	18"	22"	5"
T9620R	50	38"	26"	13"	8"
T5192A	50	38"	19"	23"	8"
T5245A	100	43"	27"	29"	8"
T9640R	110	38"	26"	26"	8"
T9640A	110	48"	35"	19"	5"
T5252A	150	48"	36"	29"	8"
T9680R	300	62"	42"	33"	8"

The fluid containment basin is designed around the need for environmental protection and to meet federal and state requirements for the storage of chemicals.

## Polyethylene Containment Basins



Model:	Gal.	Len.	Wid.	Dia.	Ht.
T6082D	90			43"	18"
T6084A	100	55"	31"		25"
T6088D	150	72"	36"		12"
T6090A	150	75"	31"		25"
T6092D	175	48"	48"		18"
T6096D	240	48"	65"		18"
T6103AG	320			72"	24"
T6104D	350	68"	68"		18"
T6124D	350	71"	71"		18"
T6112D	450			75"	31"
T6091A	610			96"	24"
T6116C	675			66"	46"
T6117C	675			82"	30"
T6124D	690	106"	59"		26"
T6125P	700	96"	72"		25"
T6128CB	950			86"	38"
T6132C	1000			84"	46"
T6128A	1150	73"	73"		66"
T6139A	1200			86"	56"
T6140A	1325	84"	84"		60"
T6164NG	2000			139"	36"
T6168CB	2075	96"	96"		62"
T6169A	2200			91"	83"
T6170N	2800			102"	104"
T6176T	3500	218"	108"		40"
T6161A	1825	96"	96"		62"

## Cone Bottom Mini-Bulk Tanks

These polyethylene tanks come with bases that allow stacking up to three high fully loaded. Forklift pockets are built in for easy loading/unloading. Both size tanks have 6" fill lids and bottom discharge.



Model:	Gal.	Dia.	Ht.
T2026R*	110	45"	38"
T2038R*	220	44"	50"



## Specialty Tanks



Model:	Type	Gal.	Len.	Wid.	Ht.	Lid
T9680A	Dock Float		48"	24"	12"	
T9687N	Free Stand	300	62"	29"	48"	16"
T9689A	Free Stand	250	62"	29"	42"	16"
T9690A	Free Stand	400	62"	29"	66"	16"
T9890N	Low Profile	1250	130"	81"	38"	16"
T9891N	Low Profile	1500	130"	81"	44"	16"
T9700N	Horiz. Box	2400	150"	90"	53"	16"
T5174A	Total Drain	35	28"	19"	20"	5"
T5198A	Total Drain	56	38"	20"	26"	5"

## Below Ground Cistern Tanks

Our below ground cisterns feature the same rugged, ribbed design found in our septic tanks. Cisterns are ideal for instances when drinking water must be hauled in, or when a well just doesn't meet consumption needs. Bulkhead fittings are available in full range of sizes to help adapt the cistern to suit specific needs or applications.

Model:	Gal.	Len.	Wid.	Ht.	Lid
T6046N	325	Sphere	54"	51"	20"
T6048N	600	101"	51"	47"	20"
T6052N	1200	102"	60"	63"	20"
T6058N	1700	135"	55"	70"	20"
T6059N	2500	159"	99"	51"	20"

## Total Drain Tanks



Model:	Gal.	Len.	Wid.	Ht.	Lid
T5025ATD	2.5	15"	7"	14"	5"
T5027A	4	11"	11"	15"	5"
T5028A	5	22"	10"	8"	5"
T5042A	10	13"	13"	21"	8"
T4012N	12	18"	14"	15"	5"
T5174A	35	28"	19"	20"	5"
T5198A	56	38"	20"	26"	5"

## Septic Tanks

For septic system replacements and new home construction, polyethylene septic tanks are designed for both durability and quick easy installation. Any septic tank can be transported to the job in a pickup truck and carried by two men. Contractors can pick up tank, pipe and fittings in one trip, and install the tank on schedule because there's no waiting for the tank to be delivered. Because our polyethylene septic tanks are rotationally molded they are seamless and water tight with no joints or seams to leak.

Model:	Gal.	Len.	Wid.	Ht.
T6020N	300	Sphere	54"	54"
T6026N	500	101"	51"	47"
T6036N	1000	102"	60"	63"
T6044N	1500	135"	55"	70"



## Pickup Truck Tanks

Model:	Gal.	Dia.	Ht.	Lid
T0904N	210	60"/51"	28"	8"
T0908N	325	62"	33"	8"
T0912N	425	65"	39"	8"

## Open Top Cylindrical Tanks



Model:	Gal.	Dia.	Ht.	Cover#
T60199C	7	10"	21"	T60199CA
T60240C	15	15"	19"	T60240CA
T60260C	17	18"	15"	T60260CA
T60280C	30	18"	29"	T60280CA
T60320C	36	15"	48"	T60320CA
T60360C	55	22"	36"	T60360CA
T60400C	73	30"	24"	T60400CA
T60440C	90	24"	48"	T60440CA
T60480C	100	28"	42"	T60480CA
T60561C	125	36"	30"	T60561CA
T60600C	150	31"	48"	T60600CA
T60680C	200	36"	48"	T60680CA
T60720C	275	42"	48"	T60720CA
T60500C	330	45"	48"	T60500CA
T60520C	360	48"	48"	T60520CA
T60530C	500	52"	60"	T60530CA
T60540C	600	48"	84"	T60540CA
T60560C	1250	69"	84"	T60560CA

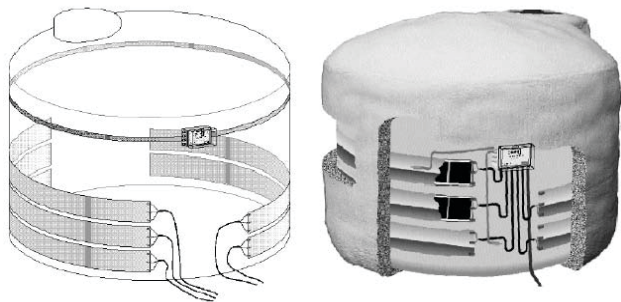

Keep your liquids at nominal temperature this winter. Custom heat tracing panels can be installed to virtually any size tanks. Latex mastic coating is applied to the external tank surface to achieve the correct "R" value. Call Today for pricing and availability.

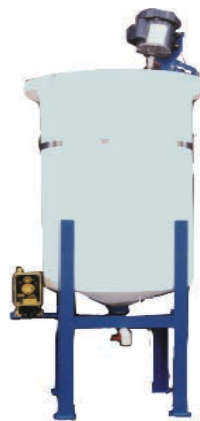

Complete Cone Bottom Mix Tanks  
With steel support stands, mixer support brackets and 115V mixer with 316 stainless steel shaft and propeller.

The tank features a cover assembly and outlet for complete drainage. The stand allows 16" clearance from the bottom of the tank outlet to the floor. Our 115V mixer is standard with a 1/3 HP electric motor, on-off switch, 8' electric cord with plug, 316 stainless steel shaft and 4" impeller.

## Complete Mix Stations

Model:	Gal.	Dia.	Ht.
Mix35	35	26"	43"
Mix55	55	26"	55"
Mix100	100	22"	60"
Mix147	147	33"	69"
Mix250	250	44"	56"
Mix500	500	55"	80"

## Cone Bottom Tanks

Model:	Gal.	Dia.	Ht.
T2008N	35	23"	27"
T2530C	55	22"	36"
T2540C	100	30"	36"
T2550U	147	31"	53"
T2560C	250	42"	46"
T2570C	500	52"	64"

## Support Stands w/ Agitator Mounts

Model:	Gal.
ST6580	55
ST6582	100
ST6584	147
ST6588	250
ST6590	500



**Advantage!**<sup>TM</sup>

## Horizontal Tank Bands

An E after the tanks size notes bands for elliptical tanks

Model:	Tank	Req.	Wid.	Ht.
ST6010	35	2	19"	19"
ST6020	65	2	22.25"	22.25"
ST6030	125	2	31.25"	31.25"
ST6040	225	2	36.75"	36.75"
ST6040	325	2	36.75"	36.75"
ST6210	425	2	47.50"	47.50"
ST6210	525	2	47.50"	47.50"
ST6010	725	3	47.50"	47.50"
ST6130	1035E	3	77"	47.25"
ST6210	1025	4	47.50"	47.50"
ST6222	1325	4	65"	64"
ST6300	1625	4	60.75"	60.75"
ST6260	1635E	4	68"	51"
ST6303	2035E	4	82"	49"
ST6301	2635E	4	87.50"	65.25"
ST6301A	3135E	4	85.50"	75.25"
ST6301B	4035E	4	89.50"	70.25"
ST6301C	5025	5	89.50"	90"

## Elliptical Tank Skids

Model:	Size	Base	Dim	# Bands
ST6603	200	24"	57"	2
ST6605	300	34"	54"	2
ST6610	500	34"	68"	3
ST6615	750	38"	78"	3
ST6620	1000	46"	72"	3

## Horizontal Tank Bases

An E after the tanks size notes bases for elliptical tanks.  
Tank bases include tank bands.

Model:	Tank	Len.	Wid.
ST6080	35	29"	22"
ST6085	65	44"	29"
ST6090	125	42"	38"
ST6095	225	64"	42.74"
ST6100	325	64"	42.75"
ST6110	525	67"	53.75"
ST6140	1035E	89"	83.50"
ST6200	1025	133"	53.75"
ST6233	1325	99"	66"
ST6241	2035E	142"	88"
ST6250	2635E	140"	94"

## Cone Bottom Stands

Model:	Fits Tank	Dia.	Clearance
ST6308	15	19"	12"
ST6309	35	24"	9"
ST6309B	60	24"	14"
ST6309AS	30 & 55	24"	14"
ST6309C	85 & 110	30"	15"
ST6309A	1000 & 1490	64"	14"
ST6310	2500 & 3000	96"	12"
ST6315	5500	119"	14"
ST6317	6000	102"	13"
ST6318	7500	142"	24"
ST6311A	1600	88"	11"
ST6314A	4900	102"	11"
ST6317A	6000	122"	10"

### Custom Herbicide Spray Equipment:

All welded unitized aluminum structure--Poly Nurse Tanks w/ baffles and agitation--Chemical Injection Systems available--Complete in-cab operation (Mid-Tech TASC 6300)

Custom Tool Boxes w/interior shelving--LED lighting and Safety Strobes--Adjustable Road-Side Boom (removable for RH or LH spraying)--Front Bumper Spray Boom w/Curb and Gutter Sprayer--Remote EPA vacuum Overhead Fill Valve--Honda Powered Centrifugal Pump--Electric Rewind Hose Reel for manual applications.





## Fiberglass Tanks & Accessories



### Heavy Duty Fiberglass Tanks

- White Gel-Coat Finish
- Complete w/Lid & Rim
- Premium Grade Resins

Model:	Gallons	Description	L x W x H Dimensions	Fill Opening
T9048T	35	Standard	28 x 23 x 21	8" Lid
T9054FRP	50	Standard	39 x 23 x 21	8" Lid
T9062FRP	100	Standard	39 x 33 x 23	16" Lid
T9072T	100	Drop Tank	67 x 20 x 20	12" Lid
T9100FRP	200	Standard	62 x 39 x 30	16" Lid
T9095T	200	Drop Tank	85 x 28 x 22	16" Lid
T9110T	300	Standard	62 x 39 x 34	16" Lid
T9068T	100	50/50 Split	39 x 33 x 23	2 - 8" Lids



### Tank Bulk Head Fittings

Model:	Size:	Model:	Size:
TA1199	1/2"	TA1205	1-1/2"
TA1200	3/4"	TA1206	2"
TA1201	1"	TA1209	3"
TA1203	1-1/4"		



### 4-Bolt Bulk Head Fittings

Model:	Size:	Model:	Size:
TA3020	1"	BBF200BD	2"
TA3030	1-1/2"	BBF300BD	3"
TA3040	2"	(Bottom Drain Fitting)	
TA3050	3"		



### Threaded Tank Lids

Model:	Size:	Description:
TL4000	5"	5" Lid w/Vent
TL4200	8"	8" Lid w/Vent & Rim
TL6015	10"	10" Lid w/Vent
TL6016	10"	10" Rim Only



### Threaded Tank Lids

Model:	Size:	Description:
TL5527	12"	12" Lid w/Vent & Rim
TL4700	16"	16" Lid w/Vent & Rim
TL5025	4"	4" Center Vent Cap



### Tank Strainer Baskets

Model:	Size:	Description:
TL3050	8"	8" Strainer Basket
TL3052	10"	10" Strainer Basket
TL3051	16"	16" Strainer Basket



### Stainless Lid Lock Assembly

Model:	Size:	Description:
CCILIDLOCK	16"	16" Locking Assy. Stainless Steel

## Valves



### Sch. 80 PVC Threaded Ball Valves

Model:	Size:	Model:	Size:
V130	1/2"	V134	1-1/2"
V131	3/4"	V135	2"
V132	1"		
V133	1-1/4"	• 235 PSI WOG	



### Brass Ball Valves (600 PSI WOG)

Model:	Size:	Model:	Size:
V158	1/4"	V162	1"
V159	3/8"	V164	1-1/4"
V160	1/2"	V162A	1-1/2"
V161	3/4"	V163	2"



### Banjo Single-Union Ball Valve

Model:	Size:	Model:	Size:
BUV050FP	1/2"	BUV150FP	1-1/2"
BUV075FP	3/4"	BUV200FP	2"
BUV100FP	1"		
BUV125FP	1-1/4"	• 100 PSI WOG	



### Banjo 4-Bolt Ball Valves (100 PSI WOG)

Model:	Size:	Model:	Size:
BV050	1/2"	BV150	1-1/2"
BV075	3/4"	BV200	2"
BV100	1"	BV200FP	2" Full Port
BV125	1-1/4"	BV300FP	3" Full Port



### 316 Stainless Steel Ball Valves (1000 PSI)

Model:	Size:	Model:	Size:
V332	1/2"	V336	1-1/2"
V333N	3/4"	V337	2"
V334	1"		
V335	1-1/4"		



### Banjo 3 Way Ball Valve (100 PSI WOG)

Model:	Size:
BV075SL	3/4"
BV100SL	1"
BV150SL	1-1/2"
BV200SL	2"



<b>Nipple</b>	
<b>Model:</b>	<b>Size:</b>
F4001A	1/8" X CLS
F4000	3/8" X CLS
F4001	1/4" X CLS
F4002	1/4" X 2 1/2"
F4002A	1/4" X 3"
F4002B	1/4" X 4"
F4002C	1/4" X 6"
F4003	1/2" X CLS
F4003D	1/2" X 2"
F4003A	1/2" X 3"
F4003B	1/2" X 4"
F4003C	1/2" X 6"
F4004	3/4" X CLS
F4004A	3/4" X 2"
F4004B	3/4" X 3"
F4004C	3/4" X 4"
F4004D	3/4" X 6"
F4004H	3/4" X 10"
F4004I	3/4" X 16"
F4005	1" X CLS
F4005A	1" X 2"
F4006B	1" X 3"
F4006	1" X 4"
F4006C	1" X 6"
F4006D	1" X 8"
F4006G	1" X 10"
F4006E	1" X 11"
F4006A	1" X 12"
F4007	1 1/4" X CLS
F4007A	1 1/4" X 2"
F4007B	1 1/4" X 3"
F4007C	1 1/4" X 4"
F4007D	1 1/4" X 6"
F4007E	1 1/4" X 8"
F4007F	1 1/4" X 10"
F4009	1 1/2" X CLS
F4010	1 1/2" X 2"
F4009A	1 1/2" X 2 1/2"
F4010C	1 1/2" X 4"
F4011	2" X CLS
F4011A	2" X 4"
F4011B	2" X 6"
F4011C	2" X 8"
F4011D	2" X 10"
F4011H	2" X 24"
F4012	3" X CLS
F4012C	3" X 6"



<b>King Nipple</b>	
<b>Model:</b>	<b>Size:</b>
F4014	1/4"
F4014A	3/8"
F4015	1/2"
F4016	3/4"
F4017	1"
F4018	1 1/4"
F4019	1 1/2"
F4020	2"
F4022	3"



<b>Coupling</b>	
<b>Model:</b>	<b>Size:</b>
F4022D	1/8"
F4023A	1/4"
F4023	3/8"
F4025	1/2"
F4026	3/4"
F4027	1"
F4028	1 1/4"
F4029	1 1/2"
F4030	2"
F4032	3"
F4032B	4"



<b>Street Elbow</b>	
<b>Model:</b>	<b>Size:</b>
F4060	1/4"
F4060A	3/8"
F4061	1/2"
F4062	3/4"
F4063	1"
F4064	1 1/4"
F4065	1 1/2"
F4066	2"
F4068	3"



<b>Tees</b>	
<b>Model:</b>	<b>Size:</b>
F4050	1/4"
F4050A	3/8"
F4051	1/2"
F4052	3/4"
F4053	1"
F4054	1 1/4"
F4055	1 1/2"
F4056	2"
F4056A	3"



<b>90 Deg. Elbow</b>	
<b>Model:</b>	<b>Size:</b>
F4033A	1/8"
F4033	1/4"
F4034	3/8"
F4035	1/2"
F4036	3/4"
F4037	1"
F4038	1 1/4"
F4039	1 1/2"
F4040	2"
F4040B	3"



<b>Plug</b>	
<b>Model:</b>	<b>Size:</b>
F4089	1/8"
F4090	1/4"
F4090A	3/8"
F4091	1/2"
F4092	3/4"
F4093	1"
F4094	1 1/4"
F4095	1 1/2"
F4096	2"
F4096A	3"



**Reducer Bushing**

Model:	Size:
F4073	1/4" X 1/8"
F4075	3/8" X 1/8"
F4072	3/8" X 1/4"
F4074	1/2" X 1/8"
F4071	1/4" X 1/2"
F4070	1/2" X 3/8"
F4077	3/4" X 1/4"
F4075A	3/4" X 3/8"
F4076	3/4" X 1/2"
F4079A	1" X 1 1/4"
F4079B	1" X 3/8"
F4080	1" X 1/2"
F4078	1" X 3/4"
F4079	1 1/4" X 3/4"
F4080A	1 1/4" X 1"
F4082C	1 1/2" X 1/4"
F4082B	1 1/2" X 3/4"
F4082	1 1/2" X 1"
F4083	1 1/2" X 1"
F4081A	2" X 1/2"
F4081	2" X 3/4"
F4085	2" X 1"
F4084A	2" X 1 1/4"
F4084	2" X 1 1/2"
F4086	3" X 2"



**45 Deg. Elbow**

Model:	Size:
F4041A	1/4"
F4041	1/2"
F4042	3/4"
F4043	1"
F4044	1 1/4"
F4045	1 1/2"
F4046	2"
F4022	3"



**Cross**

Model:	Size:
F4058	1/4"
F4058A	1/2"
F4059A	3/4"
F4059	1"
F4059C	1 1/2"
F4057	2"



**Cap**

Model:	Size:
F4097A	1/2"
F4097	3/4"
F4097B	1"
F4097C	1 1/4"
F4097D	1 1/2"
F4098	2"



**Union**

Model:	Size:
F4099D	3/4"
F5000	1"
F4099A	1 1/4"
F5001	1 1/2"
F4099	2"

**Pro Series Lawn Care Spray Equipment:**

- All welded unitized aluminum structure
- Painted aluminum on-deck tool boxes
- Long lasting fiberglass nurse and drop tanks
- Custom interior shelving
- LED lighting
- Aluminum diamond plate deck
- Curbside operator controls
- Aluminum roll-up overhead doors on tool boxes
- Remote actuated overhead fill valves
- Advertising space on roll up doors





**Nipple**

Model:	Size:
BNIP038-SH	3/8" X Short
BNIP050-SH	1/2" X Short
BNIP050-3	1/2" X 3"
BNIP075-SH	3/4" X Short
BNIP075-4	3/4" X 4"
BNIP075-6	3/4" X 6"
BNIP100-SH	1" X Short
BNIP100-4	1" X 4"
BNIP100-6	1" X 6"
BNIP125-SH	1 1/4" X Short
BNIP125-4	1 1/4" X 4"
BNIP125-6	1 1/4" X 6"
BNIP150-SH	1 1/2" X Short
BNIP150-3	1 1/2" X 3"
BNIP150-4	1 1/2" X 4"
BNIP150-5	1 1/2" X 5"
BNIP150-6	1 1/2" X 6"
BNIP200-SH	2" X Short
BNIP200-4	2" X 4"
BNIP200-6	2" X 6"
BNIP300-SH	3" X Short
BNIP300-4	3" X 4"
BNIP300-6	3" X 6"
BNIP400-SH	4" X Short



**Reducer Nipple**

Model:	Size:
BRN050-038	1/2" X 3/8"
BRN075-050	3/4" X 1/2"
BRN100-050	1" X 1/2"
BRN100-075	1" X 3/4"
BRN125-075	1 1/4" X 3/4"
BRN125-100	1 1/4" X 1"
BRN150-100	1 1/2" X 1"
BRN150-125	1 1/2" X 1 1/4"
BRN200-125	2" X 1 1/4"
BRN200-150	2" X 1 1/2"
BRN300-200	3" X 2"

**Hose Barbs - Straight**

(Note: the first dimension is NPT thread and the second is the Hose Size.)

Model:	Size:
BHB025	1/4" X 1/4"
BHB025/038	1/4" X 3/8"
BHB038	3/8" X 3/8"
BHB038/050	3/8" X 1/2"
BHB050/038	1/2" X 3/8"
BHB050	1/2" X 1/2"
BHB050/075	1/2" X 3/4"
BHB075/038	3/4" X 3/8"
BHB075/050	3/4" X 1/2"
BHB075/058	3/4" X 5/8"
BHB075	3/4" X 3/4"
BHB075/100	3/4" X 1"
BHB100/075	1" X 3/4"
BHB100	1" X 1"
BHB100/125	1" X 1 1/4"
BHB125/075	1 1/4" X 3/4"
BHB125/100	1 1/4" X 1"
BHB125	1 1/4" X 1 1/4"
BHB125/150	1 1/4" X 1 1/2"
BHB150/100	1 1/2" X 1"
BHB150/125	1 1/2" X 1 1/4"
BHB150	1 1/2" X 1 1/2"
BHB150/200	1 1/2" X 2"
BHB200/150	2" X 1 1/2"
BHB200	2" X 2"
BHB300	3" X 3"
BHB400	4" X 4"



**Cross**

Model:	Size:
BCR075	3/4"
BCR100	1"
BCR125	1 1/4"
BCR150	1 1/2"
BCR200	2"



**Coupling**

Model:	Size:
BCPLG038	3/8"
BCPLG050	1/2"
BCPLG075	3/4"
BCPLG100	1"
BCPLG125	1 1/4"
BCPLG150	1 1/2"
BCPLG200	2"
BCPLG300	3"



**Pipe Plug**

Model:	Size:
BPLUG050	1/2"
BPLUG075	3/4"
BPLUG100	1"
BPLUG125	1 1/4"
BPLUG150	1 1/2"
BPLUG200	2"
BPLUG300	3"



**Reducer Coupling**

Model:	Size:
BRC100-075	1" X 3/4"
BRC150-100	1 1/2" X 1"
BRC150-125	1 1/2" X 1 1/4"
BRC200-100	2" X 1"
BRC200-125	2" X 1 1/4"
BRC200-150	2" X 1 1/2"
BRC300-200	3" X 2"



**Hose Barb - 90 Deg.**

(Note: the first dimension is NPT thread and the second is the Hose Size.)

Model:	Size:
BHB-025-90	1/4" X 1/4"
BHB-038-90	3/8" X 3/8"
BHB-050/038-90	1/2" X 3/8"
BHB-050-90	1/2" X 1/2"
BHB-050/075-90	1/2" X 3/4"
BHB-075/050-90	3/4" X 1/2"
BHB-075-90	3/4" X 3/4"
BHB-075/100-90	3/4" X 1"
BHB-100/075-90	1" X 3/4"
BHB-100-90	1" X 1"
BHB-100/125-90	1" X 1 1/4"
BHB-125/100-90	1 1/4" X 1"
BHB-125-90	1 1/4" X 1 1/4"
BHB-150-90	1 1/2" X 1 1/2"
BHB-200-90	2" X 2"
BHB-300-90	3" X 3"



**Hose Barb to Hose Barb**

Model:	Size:
BHM050	1/2" X 1/2"
BHM075	3/4" X 3/4"
BHM100	1" X 1"
BHM125	1 1/4" X 1 1/4"
BHM150	1 1/2" X 1 1/2"
BHM200	2" X 2"
BHM300	3" X 3"



**Pipe Cap**

Model:	Size:
BCAP075	3/4"
BCAP100	1"
BCAP150	1 1/2"
BCAP200	2"
BCAP300	3"



**Hose Barb Tee**

Model:	Size:
BHT-050-038	1/2" X 1/2" X 3/8"
BHT-050-075	1/2" X 1/2" X 3/4"
BHT-075-050	3/4" X 3/4" X 1/2"
BHT-075	3/4"
BHT-100-075	1" X 1" X 3/4"
BHT-100	1"



**Street Elbow 90**

Model:	Size:
BSL038-90	3/8"
BSL050-90	1/2"
BSL075-90	3/4"
BSL100-90	1"
BSL125-90	1 1/4"
BSL150-90	1 1/2"
BSL200-90	2"
BSL300-90	3"



**Pipe Tee**

Model:	Size:
BTEE038	3/8"
BTEE050	1/2"
BTEE075	3/4"
BTEE100	1"
BTEE125	1 1/4"
BTEE150	1 1/2"
BTEE200	2"
BTEE300	3"



**Reducer Bushing**

Model:	Size:
BRB038-025	3/8" X 1/4"
BRB050-025	1/2" X 1/4"
BRB050-038	1/2" X 3/8"
BRB075-018	3/4" X 1/8"
BRB075-025	3/4" X 1/4"
BRB075-038	3/4" X 3/8"
BRB075-050	3/4" X 1/2"
BRB100-018	1" X 1/8"
BRB100-025	1" X 1/4"
BRB100-050	1" X 1/2"
BRB100-075	1" X 3/4"
BRB125-075	1 1/4" X 3/4"
BRB125-100	1 1/4" X 1"
BRB150-075	1 1/2" X 3/4"
BRB150-100	1 1/2" X 1"
BRB150-125	1 1/2" X 1 1/4"
BRB200-075	2" X 3/4"
BRB200-100	2" X 1"
BRB200-125	2" X 1 1/4"
BRB200-150	2" X 1 1/2"
BRB300-150	3" X 1 1/2"
BRB300-200	3" X 2"



**Pipe Elbow 90**

Model:	Size:
BEL050-90	1/2"
BEL075-90	3/4"
BEL100-90	1"
BEL125-90	1 1/4"
BEL150-90	1 1/2"
BEL200-90	2"
BEL300-90	3"



**Hose Barb 90**

Model:	Size:
BHBEL-100-90	1"



### Flange Clamps

Model:	Size:
BFC100	1" FP
BFC200	2" SP
BFC220	2" FP
BFC300	3" FP



### Flange x 90 Hose Barb Elbow

Model:	Size:
BM100BRB90	1"
BM200BRB90	2" SP
BM220BRB90	2" FP
BM300BRB90	3"



### Flange Gaskets

Model:	Size:
B100G	1"
B150G	2" SP
B200G	2" FP
B300G	3" FP



### Flange x Hose Barb

Model:	Size:
BM100BRB	1"
BM200BRB	2" SP
BM220BRB	2" FP
BM300BRB	3"



### Flanged Poly Check Valves

Model:	Size:
BMCV100	1"
BMCV200	2"
BMCV220	2" FP



### Flanged Cross

Model:	Size:
BM100CR	1"
BM200CR	2" SP
BM220CR	2" FP
BM300CR	3"



### Flange x Male NPT Thread

Model:	Size:
BM100MPT	1"
BM200MPT	2" SP
BM220MPT	2" FP
BM300MPT	3"



### 90 Deg Flanged Coupling

Model:	Size:
BM100CPG90	1"
BM200CPG90	2" SP
BM220CPG90	2" FP
BM300CPG90	3"



### Flange x Female NPT Thread

Model:	Size:
BM100FPT	1"
BM200FPT	2" SP
BM220FPT	2" FP
BM300FPT	3"



### 2" Full Port Stubby Valve

Model:	Size:
BMVS220CF	2" FP



### Flanged Tee

Model:	Size:
BM100TEE	1"
BM200TEE	2" SP
BM220TEE	2" FP
BM300TEE	3"



### 4 & 6 Bolt Valves

Model:	Size:
BMV100CF	1"
BMV200CF	2" SP
BMV220CF	2" FP
BMV300CF	3" FP



### Flanged Couplings

Model:	Size:
BM100CPG	1"
BM200CPG	2" SP
BM220CPG	2" FP
BM300CPG	3"



### Flanged Tee

Model:	Size:
BM100CPG45	1"
BM220CPG45	2" FP
BM300CPG45	3"

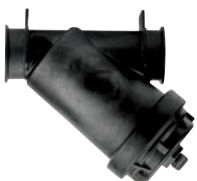

### Line Strainers

Model:	Size:
BMLS200-12	2"
BMLS222-16	2" FP
BMLS300-12	3"



### Flange x Male NPT Thread SS

Model:	Size:
BM220MPTSS	2" FP
BM300MPTSS	3"

## Cam Action Couplers

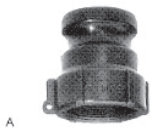

### Type "A" Female Pipe x Male Cam-Lock

Model:	Size:	Model:	Size:
B075A	3/4"	B200A	2"
B100A	1"	B300A	3"
B125A	1-1/4"		
B150A	1-1/2"		



### Type "B" Male Pipe x Female Cam-Lock

Model:	Size:	Model:	Size:
B075B	3/4"	B200B	2"
B100B	1"	B300B	3"
B125B	1-1/4"		
B150B	1-1/2"		



### Type "C" Hose x Female Cam-Lock

Model:	Size:	Model:	Size:
B075C	3/4"	B200C	2"
B100C	1"	B300C	3"
B125C	1-1/4"		
B150C	1-1/2"		



### Type "D" Female Pipe x Female Cam-Lock

Model:	Size:	Model:	Size:
B075D	3/4"	B150D	1-1/2"
B100D	1"	B200D	2"
B125D	1-1/4"	B300D	3"



### Type "E" Hose x Male Cam-Lock

Model:	Size:	Model:	Size:
B075E	3/4"	B200E	2"
B100E	1"	B300E	3"
B125E	1-1/4"		
B150E	1-1/2"		



### Type "F" Male Pipe x Male Cam-Lock

Model:	Size:	Model:	Size:
B075F	3/4"	B200F	2"
B100F	1"	B300F	3"
B125F	1-1/4"		
B150F	1-1/2"		



### Type "PL" Male Cam-Lock Plug

Model:	Size:	Model:	Size:
B075PL	3/4"	B200PL	2"
B100PL	1"	B300PL	3"
B150PL	1-1/2"		



### Type "CAP" Male Pipe x Male Cam-Lock

Model:	Size:	Model:	Size:
B075CAP	3/4"	B200CAP	2"
B100CAP	1"	B300CAP	3"
B150CAP	1-1/2"		



### Type "90°A" Female Pipe x Male Cam-Lock

Model:	Size:
N150A90	1-1/2" 90° A Coupler
N200A90	2" 90° A Coupler



### Type "90°C" Hose x Female Cam-Lock

Model:	Size:
N150C90	1-1/2" 90° C Coupler
N200C90	2" 90° C Coupler



### Type "90°D" Female Pipe x Female Cam-L

Model:	Size:
N150D90	1-1/2" 90° D Coupler
N200D90	2" 90° D Coupler



### Type "90°F" Male Pipe x Male Cam-Lock

Model:	Size:
N150F90	1-1/2" 90° F Coupler
N200F90	2" 90° F Coupler

## No-Spill Dry Disconnects

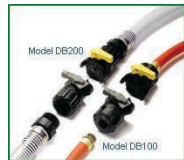

### Sure Stop™ Full-Flow Dry Disconnect

Model:	Size:
BDB100	1" FPT Complete Coupler M/F
BDB100M	1" FPT Male Coupler
BDB100F	1" FPT Female Coupler



### Banjo Dry-Mate™ Dry Disconnects

Model:	Size:
BDM150A	1-1/2" Male Dry-Mate x FPT
BDM150D	1-1/2" Female Dry-Mate x FPT
BDM200A	2" Male Dry-Mate x FPT
BDM200D	2" Female Dry-Mate x FPT

## Backpack & Spot Sprayers



### 2 Gallon Super Sprayer

- Model: FSPS0010A
- Funnel Fill Opening
  - 48" Braided Hose
  - 18" Poly Wand
  - Flat and Cone Nozzles Included



### 4 Gallon SP1 Bak-Pak Sprayer

- Model: FSPS003
- 20" Brass Wand
  - Viton® Seals
  - Includes 3 Flat Fan Nozzles
- Diaphragm Kit Model: FSPS4KIT**



### 4 Gallon Commercial Bak-Pak Sprayer

- Model: FSPS001
- Extra Large Fill Opening
  - 48" PVC Hose
  - 20" Poly Wand
  - Bonus 4 Setting Nozzle



## Flow Meters



### Badger Mag Meters

Model: Description:  
DI2152KIT • 2" Meter w/reset  
• Teflon Liner



### Sotera Digital Flow Meter 2-20 GPM

Model: Description:  
MS825 • Easy read LCD display  
• Polypropylene body with a Ryton chamber & chemical seal  
• 1" NPT Inlet and Outlet



### GPI Digital Flow Meter (Stainless)

Model: Description:  
M404 • Stainless 3/4" - 2 to 20 GPM  
M405 • Stainless 1" - 3 to 30 GPM  
M406 • Stainless 2" - 30 to 300 GPM



### Bulk Flow Meters (Aluminum)

Model: Description:  
MS826A • Aluminum 1-1/2" Ports  
• 60 GPM Flow  
MS826C • Aluminum 2" Ports  
• 100 GPM Flow



### Banjo Magnetic Flow Meter

Model: Description:  
BMFM100 • 1" Magnetic Meter  
(Flanged) • Digital  
BFM100 • All Poly  
(Threaded) • 2-110 GPM Range



### Banjo Magnetic Flow Meter

Model: Description:  
BMFM220 • 2" Magnetic Meter  
(Flanged) • Digital  
BMFM220KIT • All Poly  
(Threaded) 2" • 30-300 GPM Range



### GPI Digital Flow Meter (Nylon)

Model: Description:  
M409 • Nylon 1" - .3 to 3 GPM  
M409A • Nylon 1" - 3 to 30 GPM  
M406A • PVC 2" - 30 to 300 GPM



### Bulk Flow Meters (Stainless)

Model: Description:  
MS826B • Stainless 2" Ports  
• 100 GPM Flow

## Pumps



### Sotera Diaphragm Transfer Pumps

Model: Description:  
MS415 12V • Pump w/Hose  
MS460 110V • Max: 13 GPM  
• 2" NPT bung Adapter  
• Santoprene Diaphragms



### Sotera Diaph. Transfer Pumps w/Meters

MS421 12V • Pump / Hose / Meter  
MS461 110V • Max: 13GPM  
• 2" NP bung adapter  
• Santoprene Diaphragms



### Sotera Chemtraveller Portable System

Model: Description:  
MS435 12V • Pump / Meter / Hoses & Storage Frame  
MS465 110V • 9' EPDM Transfer Hose  
• Model 825 digital flow meter



### 2" Pump/Motor/Stand Kits

80PUMPASS25P • 2" Poly, SS, Cast I.  
80PUMPASS25SS • 5 hp 3 ph Motors  
80PUMPASS25CI • Coupling Guard & Stand  
• Single Phase Option



### Jet Agitation Eductors

Model: Description:  
BX2MP • 3/4" Poly Eductor  
BX3MP • 1" Poly Eductor  
BX4MP • 1 1/2" Poly Eductor



### 3" Pump/Motor/Stand Kits

80PUMPASS310P • 2" Poly, SS, Cast I.  
80PUMPASS310SS • 5 hp 3 ph motors  
80PUMPASS310CI • Coupling Guard & Stand



### Sump Pump

Model: Description:  
PM13YU75 • 1/2" HP SS w/Float  
PM13YU76 • 3/4" HP SS w/Float



### Metering Injectors

P0003 • Dosage Rate .2% to 2%  
P0002A • Dosage Rate .2% to 1.6%  
P0000 • Dosage Rate 2% to 10%  
(Please call for application info.)





## Equipment for **NEW** or upgrading old systems

- Design and layout assistance
- Pre-assembled kit or components only
- Plumbing packages
- Field and site visits



### Stainless Steel Work Stations

81MLWORKTABLE1

- 96"l x 60"h x 30"w
- Stainless Sink
- PVC Deck & Splash

81MLWORKTABLE



### Aluminum Storage Shelving

81MLSHELF3

- 96"l x 60"h x 18"w
- 1200 lb rated
- Aluminum Frame



### Emergency Eyewash Showers

- CCIFSG1600S • All Stainless Steel  
Wall Mount  
CCIFSG1600S-A  
Floor Mount



### Sump Boxes / Grates & Covers

80SUMPBOX222SS1  
w/ 2-1" x 1 1/2" fittings

80SUMPBOX222SS  
w/ no fittings



80GRATETEC22SSNF  
Cover w/ no fittings



80GRATEC22SS  
w/ 3" coupling boot

80GRATEFR22  
2" Frame for concrete

### Chemical Pre-Mix Tank Systems



- |                          |             |
|--------------------------|-------------|
| 80110MNF                 | 110 Gallon  |
| 80220MNF                 | 220 Gallon  |
| 80300MNF                 | 300 Gallon  |
| w/ pump tank eductor kit |             |
| 80500CBMNF DL            | 500 Gallon  |
| 80750CBMNF DL            | 750 Gallon  |
| 801050CBMNF DL           | 1050 Gallon |

### Chemical Eductors

Add chemicals, dry products into spray and mix tanks

- |                |           |
|----------------|-----------|
| 80EDUCTORBJ10  | 10 Gallon |
| 80EDUCTOR BJ15 | 15 Gallon |
| 80EDUCTORBJ35  | 35 Gallon |



With Bypass Agitation  
All Stainless Framing

### Retractable Loadout Hose Kits

Load Out Swing Arms  
for filling





## Storage - Mixing - Dispensing



- Facility design assistance
- Pre-assembled systems
- In-field site and efficiency evaluations
- Pre-packaged standard kits for multiple sites



- Complete turn key systems small or large
- Manual or automated systems
- Individual components
- Upgrades to expand existing facilities

### Eductor kits



- Features:
- Stainless Frame
  - Poly Cone bottom tanks
  - By Pass
  - Hose Barbs

80EDUCTORBJ10  
80EDUCTORBJ15  
80EDUCTORBJ35

### Pump kits

Includes: 3ph motor, SS stand w/legs, guard, couplings



- 2" Cast Iron, Stainless Steel or Poly centrifugal pumps w/ viton seals
  - 3" Cast Iron or Stainless Steel centrifugal pumps w/viton seals
- 80PUMPASS25CI  
80PUMPASS25SS  
80PUMPASS25P  
80PUMPASS310CI  
80PUMPASS310SS

### Flow Meters



- 2" Mag-meter, Teflon liner
- 2" FPT Threaded flange
- Re-setable
- Requires 110v power

DI2152KIT

Available in  
single phase

### Threaded Banjo Mag Meter



BFM100 • 1" 2-110 gpm rated

### Flanged Banjo Mag Meters



BMFM100 • 1" 2-110 gpm rated  
BMFM220 • 2" 5-300 gpm rated  
BMFM300 • 3" 14-670 gpm rated

### Sotera Meters



MS825 • 1" 2.20 gpm rated  
MS826C • 2" Aluminum  
MS826B • 2" Stainless Steel

### Pump fitting Kits



80PLUMBKIT • 2" Suction, 2" Discharge manifold fittings, valve  
80PLUMBKIT3 • 3" Suction, 1-3" Discharge 1-2" Discharge, valve

### Bag Filters



### Sump Covers



### Sump Boxes



**Mix-n-Fill Chemical Pre-Mix Tank kits**



**Features:**

- 400 Series 110 V Sotera Diaphragm Pump
- Heavy duty cone bottom mini-bulk style tank w/ fork pockets\* & 8" access lid
- 12' chemical transfer discharge hose w/nozzle valve & holder
- Simple selector valve to set in mix or dispense operation.
- Vortex jet agitation system for complete mixing of product before dispensing
- 10-15 gpm flow rate\*/electric
- 10-30 gpm flow rate\*/ air (optional)
- On/off switch with overload protection
- 6' 3 wire 110 volt cord w/ plug
- 2" access fitting for water fill optional water meter kit adders

**Pump may run dry without damage**

**Larger Sizes Available**

**Tanks**

- 80110MNF 110 Gallon 110V pump (44" wide x 43" ht)
- 80220MNF 220 Gallon 110V pump (44" wide x 67" ht)
- 80300MNF 300 Gallon 110V pump (49" wide x 73"ht)

**Larger Sizes: Cone Bottom Tank w/Pump/Eductor Kit**

- 80500MNF DL 500 Gallon
- 80750MNF DL 750 Gallon
- 801050MNF DL 1050 Gallon

Optional Pump Available

**Customized Tank Mixing & Pumping Systems Available**



Jet Agitation Nozzles

- Water Meters **Adder/inlet only** (Optional)
- MNFKITA 1" Meter Kit / 20 gpm
- MNFKITB 2" Meter Kit/30-200 gpm

**Electronic Pre-set Dosage Device for Chemical Transfer**



80QUANTOFILLAHV  
80QUANTOFILLALV

80QUANTOFILL12V  
80QUANTOFILL110  
(Meter & Control box only-  
no pump, no plumbing)

- Transfers pre-set amount and shuts off
- HV transfer maximum rate 12 GPM
- LV transfer maximum rate 3 GPM
- Units of measure: oz., ml, gallons
- 110 volt power
- For drums, minibulks, & tanks
- Also available in 12 volt/ multi-unit combinations

**Multi Chemical Transfer Kits**



Sotera 400 series pump, 825 digital manual resettable flow meter, 10-12 gpm transfer rate, stainless mounting stand/legs, plumbing kits for combination plumbing kits for 1, 2 or 4 outlets, 1 or 2 inlet ports

- 80MCTS11
- 80MCTS21
- 80MCTS42

1-inlet w/ drum stinger & 2" female QC for minibulk tank hook-up, 1-12' discharge hose w/ ball valve & nozzle

**Equipment Wash Depot Systems**



Enclosed Reclaim

**Ozone, Biological & Hydro-Aeration/Filtration  
Provides Primary Water Treatment**

- All aluminum construction
- Higher water volume processing rates
- Complete enclosed skids



Open Reclaim



Discharge



Wash Reels

**Containment / Wash Pads**



- Variety of lengths & widths
- Center and side drains
- Aluminum and steel construction



**Self Contained  
Chemical Buildings**

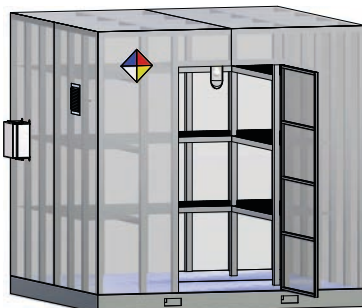

- Standard or custom built sizes
- All Aluminum construction



Water Filter  
Kits



Conventional Tank Design

**Standard Features:**

- Chemical Resistant Polyethylene Tanks
- Large Fill-Well for Easy Access
- All Welded Corrosion Resistant T6061 Aluminum Frame
- Remote Mounted Suction Strainer w/Tank On/Off Valve
- All Plumbing is Poly or Stainless Steel
- Easy Start Honda Engines
- Commercial Duty Pumps
- Adjustable High Pressure Jet Agitation
- Low Profile Tank Design
- Premium Grade Spray Hose
- Easy Access Frame for Regular Maintenance
- Liquid Filled Pressure Gauge
- Factory Tested & Ready for Operation

**Single Tank Skids**

Part Number	Tank and Pump (gpm,psi)	Engine
7SLP050-CR-160	50 Gallon, Roller Pump	Honda GX160 Man.
7SLP050-CR-160E	50 Gallon, Roller Pump	Honda GX160 Elec.
7SLP100-CR-160	100 Gallon, Roller Pump	Honda GX160 Man.
7SLP100-CR-160E	100 Gallon, Roller Pump	Honda GX160 Elec.
7SLP050-K43-160	50 Gallon, K-43 (10.5, 560)	Honda GX160 Man.
7SLP050-K43-160E	50 Gallon, K-43 (10.5, 560)	Honda GX160 Elec.
7SLP100-K43-160	100 Gallon, K-43 (10.5, 560)	Honda GX160 Man.
7SLP100-K43-160E	100 Gallon, K-43 (10.5, 560)	Honda GX160 Elec.
7SLP100-K55-240	100 Gallon, K-55 (15, 560)	Honda GX240 Man.
7SLP100-K55-240E	100 Gallon, K-55 (15, 560)	Honda GX240 Elec.
7SLP200-K55-240	200 Gallon, K-55 (15, 560)	Honda GX240 Man.
7SLP200-K55-240E	200 Gallon, K-55 (15, 560)	Honda GX240 Elec.
7SLP300-K55-240	300 Gallon, K-55 (15, 560)	Honda GX240 Man.
7SLP300-K55-240E	300 Gallon, K-55 (15, 560)	Honda GX240 Elec.
7SLP200-K75-390	200 Gallon, K-75 (20, 560)	Honda GX390 Man.
7SLP200-K75-390E	200 Gallon, K-75 (20, 560)	Honda GX390 Elec.
7SLP300-K75-390	300 Gallon, K-75 (20, 560)	Honda GX390 Man.
7SLP300-K75-390E	300 Gallon, K-75 (20, 560)	Honda GX390 Elec.
7SLP400-K75-390	400 Gallon, K-75 (20, 560)	Honda GX390 Man.
7SLP400-K75-390E	400 Gallon, K-75 (20, 560)	Honda GX390 Elec.
7SLP500-K75-390	500 Gallon, K-75 (20, 560)	Honda GX390 Man.
7SLP500-K75-390E	500 Gallon, K-75 (20, 560)	Honda GX390 Elec.
7SLP300-K120-670E	300 Gallon, K120 (35, 700)	Honda GX670 Elec.
7SLP400-K120-670E	400 Gallon, K120 (35, 700)	Honda GX670 Elec.
7SLP500-K120-670E	500 Gallon, K120 (35, 700)	Honda GX670 Elec.



Long Profile Tank Design



**Spray Rig - Hose Reels/Hose Titan/Hannay**

7SHR38300M	3/8" Ag Hose 560 PSI 300ft Manual
7SHR38300E	3/8" Ag Hose 560 PSI 300ft Electric
7SHR12300M	1/2" Ag Hose 560 PSI 300ft Manual
7SHR12300E	1/2" Ag Hose 560 PSI 300ft Electric
7SHR12300HPE	1/2" Ag Hose 800 PSI 300ft Electric
7SHR58300E	5/8" Ag Hose 560 PSI 300ft Electric
7SHR58300HPE	5/8" Ag Hose 800 PSI 300ft Electric
7SHR34300HPE	3/4" Ag Hose 800 PSI 300ft Electric

**Roller Guides Included on Electric Reels**  
**Optional Hose Lengths available**





**Multi-Tank Skids**

Part Number	Tank and Pump (gpm,psi)	Engine
7S10050-K43-160	100/50 Gallon, K-43 (10.5, 560)	Honda GX160 Man.
7S10050-K43-160E	100/50 Gallon, K-43 (10.5, 560)	Honda GX160 Elec.
7S20050-K43-160	200/50 Gallon, K-43 (10.5, 560)	Honda GX160 Man.
7S20050-K43-160E	200/50 Gallon, K-43 (10.5, 560)	Honda GX160 Elec.
7S10050-K55-240	100/50 Gallon, K-55 (15, 560)	Honda GX240 Man.
7S10050-K55-240E	100/50 Gallon, K-55 (15, 560)	Honda GX240 Elec.
7S20050-K55-240	200/50 Gallon, K-55 (15, 560)	Honda GX240 Man.
7S20050-K55-240E	200/50 Gallon, K-55 (15, 560)	Honda GX240 Elec.
7S100100-K55-240	100/100 Gallon, K-55 (15, 560)	Honda GX240 Man.
7S100100-K55-240E	100/100 Gallon, K-55 (15, 560)	Honda GX240 Elec.
7S200100-K55-240	200/100 Gallon, K-55 (15, 560)	Honda GX240 Man.
7S200100-K55-240E	200/100 Gallon, K-55 (15, 560)	Honda GX240 Elec.
7S20050-K75-390	200/50 Gallon, K-75 (20, 560)	Honda GX390 Man.
7S20050-K75-390E	200/50 Gallon, K-75 (20, 560)	Honda GX390 Elec.
7S100100-K75-390	100/100 Gallon, K-75 (20, 560)	Honda GX390 Man.
7S100100-K75-390E	100/100 Gallon, K-75 (20, 560)	Honda GX390 Elec.
7S200200-K75-390	200/200 Gallon, K-75 (20, 560)	Honda GX390 Man.
7S200200-K75-390E	200/200 Gallon, K-75 (20, 560)	Honda GX390 Elec.
7S300100-K75-390	300/100 Gallon, K-75 (20, 560)	Honda GX390 Man.
7S300100-K75-390E	300/100 Gallon, K-75 (20, 560)	Honda GX390 Elec.
7S300100-K120-670E	300/100 Gallon, K120 (35, 700)	Honda GX670 Elec.
7S400100-K120-670E	400/100 Gallon, K120 (35, 700)	Honda GX670 Elec.
7S500100-K120-670E	500/100 Gallon, K120 (35, 700)	Honda GX670 Elec.
7S315-K75-390E	300/100/50 Gallon, K75 (20, 560)	Honda GX390 Elec.
7S325-K75-390E	300/200/50 Gallon, K75 (20, 560)	Honda GX390 Elec.
7S315-K120-670E	300/100/50 Gallon, K120 (35, 700)	Honda GX670 Elec.
7S425-K120-670E	400/200/50 Gallon, K120 (35, 700)	Honda GX670 Elec.
7S525-K120-670E	500/200/50 Gallon, K120 (35, 700)	Honda GX670 Elec.

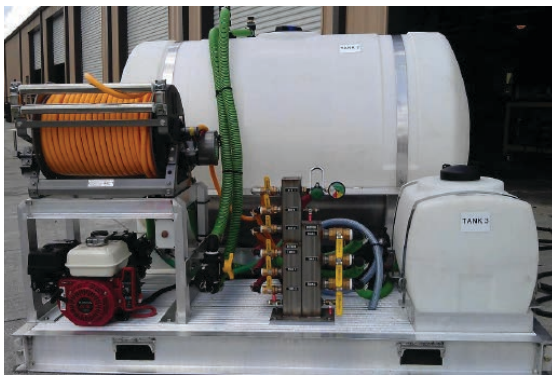

**See Page 26 for Hose Reels and Hose**

**Chemical Containers, Inc. 6 - 25 Gallon Lawn & Turf Sprayers**

Standard Features:

- Chemical Resistant Polyethylene Tank
- Seamless No-Leak Construction
- Quick Drain Fitting for Easy Cleaning
- Calibration Scale Molded into Tank
- Heavy Duty 12V Diaphragm Pump
- Pro-Trigger Spray Gun w/ Adjustable Tip
- 5" Fill-Well with Easy Grip Lid
- 25' of 3/8" Chemical Spray Hose
- All Stainless Steel Fasteners
- 9' Wiring Harness w/Battery Clips
- Systems are Factory Tested & Ready for Operation



Our portable spraying systems are quality engineered and manufactured to provide years of dependable service with low maintenance. Their lightweight portable design makes these units perfect for a wide range of spraying applications.

Models:	Description:	PSI / GPM
CCI6	6 Gallon Spot Sprayer, 25 ft hose, poly gun.	60 • 1.8
CCI14ECO	14 Gallon Economy Spot Sprayer, 10ft hose, poly gun.	60 • 1.0
CCI25ECO	25 Gallon Economy Spot Sprayer, 10ft hose, poly gun.	60 • 1.0
CCI14	14 Gallon Spot Sprayer, 25 ft hose, poly gun.	60 • 1.8
CCI25	25 Gallon Spot Sprayer, 25 ft hose, poly gun.	60 • 1.8
CCI15	15 Gallon Spot Sprayer w/frame, 25 ft hose, alum. gun.	60 • 1.8

### Custom Built Sprayers:

We specialize in custom built spray rigs. The previous pages of spray skids are suggestions of the many sizes we offer. Call us to configure your spray skid to fit your needs. Our sales force is ready to assist you with experience that spans 35 years.

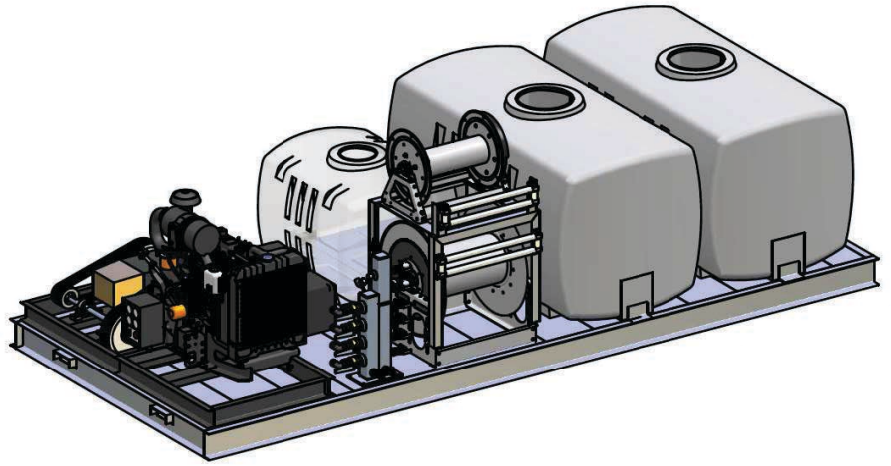

For more information please visit:  
[www.chemicalcontainers.com](http://www.chemicalcontainers.com)



**Multi-Size Leg Tank Sprayer**

- Manual start Honda GX160 4.8HP with Banjo 2"x2" poly self-priming pump
- (Tank size of your choice) leg tank with built in baffles and 16" lid
- All aircraft grade aluminum frame with built in fork lift pockets
- Single lane mile boom 7' aluminum covered Reese plug in boom with 1 1/2" PVC Sch80 boom with quick disconnect fitting to plug into plumbing
- 2 GPM solid stream stainless spray nozzles, (2) Boom Buster nozzles with manual ball valve controls, and BEX clamp bodies for easy removal (Unit can spray 3 lanes)
- Wireless on/off switch for banjo poly heavy duty electric shut off valve (valve has on/off indicator) wire harness w/ quick disconnect plugs
- Stainless steel pressure gauge
- Remote tank fill fitting w/quick coupling fitting to use on board pump to fill unit

**CCI Self-Loading Anti-Ice Systems**

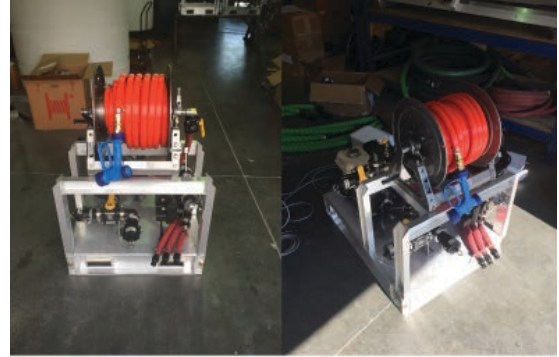

Item Number	Quantity	Title	Quantity	Item Number	Title	Quantity
1	1	RESEALABLE HOSE	1	2	BRASS HOSE CONNECTOR	1
2	1	RESEALABLE HOSE	1	3	BRASS HOSE CONNECTOR	1

NOTES:  
 1. SEE DRAWING FOR DIMENSIONS  
 2. SEE DRAWING FOR DIMENSIONS  
 3. SEE DRAWING FOR DIMENSIONS  
 4. SEE DRAWING FOR DIMENSIONS

**Slide-in Skids**

- Electric start Honda GX160 4.8HP with Banjo 2inx2in poly self-priming pump
- 8' Long Boom with Stainless Steel Pipe and fittings. 8 turrets, Boom Busters nozzles and 3 lane MicroTrak controls.
- 2 GPM solid stream stainless spray nozzle, poly covered stainless flat fan nozzles, and poly Tri-Stream nozzles, w/quick caps in a turret nozzle body w/ diaphragm checks
- Cab control for boom with(3) on/off switches for TeeJet 450 manifold poly heavy duty electric shut off valves, wire harness w/ quick disconnect plugs
- Manifold style poly plumbing ( stainless clamped together fittings, easy repair)
- Hannay electric hose reel with 75ft of 3/4" orange AG hose and heavy duty Udor blue adjustable salt gun.
- Remote tank fill fitting w/quick coupling fitting (to use pump to fill unit)
- All Aircraft grade aluminum skid, fork lift pockets, and tie down tabs, complete user's manual and full 1 year warranty



**CCI Brine Makers**



**1500 Gallon**

- 1500 Gallon square tank with aluminum receiving top for salt loader with all steel frame to protect tank from tip-over after complete empty.
- Unit has 1" eductor nozzles and 3" full port valves for control of all operations.
- Bottom drain for rinsing out materials and adjustable suction ports for dispensing product.
- 10HP 240 volt 3 phase motor with starter and 3" all stainless steel pump and motor producing 340 gallons per minute for agitation and product transfer.
- Salt percentage meter with case.
- Off-load meter.
- Unit will produce 3000 gallons of brine each hour if the unit has sufficient water available.
- Unit includes all hoses needed to hook into current holding tanks, installation instructions, and user manual.



**300 Gallon**

- 300 Gallon tote tank w/steel frame
- 2HP motor with 1 1/2" stainless steel pump.
- 60 GPM discharge & agitation.
- Unit produces 900 GPH
- Clean out valve
- Tip-over clean out
- Portable with fork pockets

**Gas Driven Tote Sprayer**

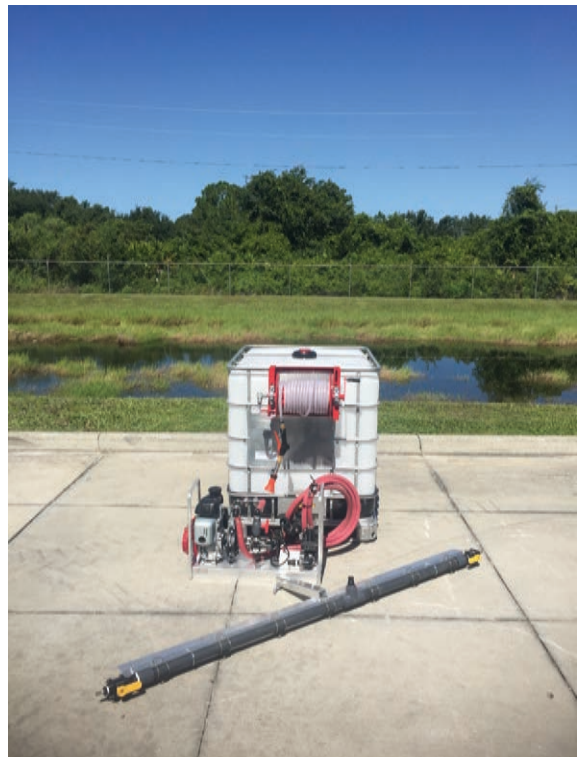

**Pump Systems**

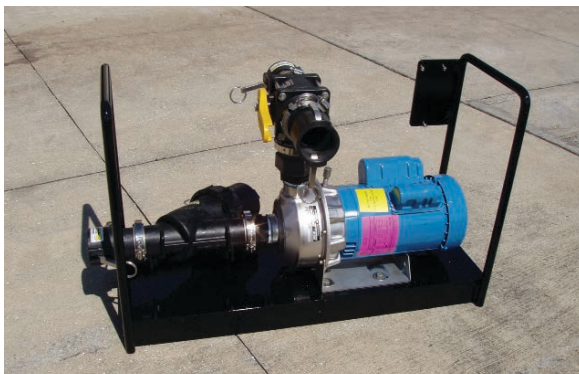



## **CCI IS YOUR FULL PARTS AND SERVICE CENTER!**

Stainless Steel Construction - Tanks, fittings, hardware and plumbing.

Rears Constant Velocity Hitch - Smooth 90 deg turns.

Rears Centrifugal Pumps - 200 psi/80 gpm

Remote Spray Control - manual, electric, hydraulic.

Double Roll-Over Nozzle Bodies - easy application switch.

33" of 38" Diameter Axial Flow Fans - fitted to stainless steel housing.

Electric Fan Clutch - On/Off control for mixing.





# CC-EYE 8000 TREE SENSE CONTROL SYSTEMS



3 eyes per side system - installed on a Rears Sprayer.

With the growing cost and new disease challenges in crop production, growers have to take advantage of every opportunity to save time and money while not sacrificing the quality of care provided to crops. Invest in the Patented Technology of Chemical Container's CC-EYE 8000 Tree Sense Control System and allow yourself as a grower to apply precise, accurate applications saving you money and time. Growers who are currently utilizing the CC-EYE 8000 Tree Sense Control System are realizing dramatic reductions in application cost and application time. Contact us today about investing in the CC-EYE 8000 Tree Sense Control System for your sprayer or fertilizer spreader.

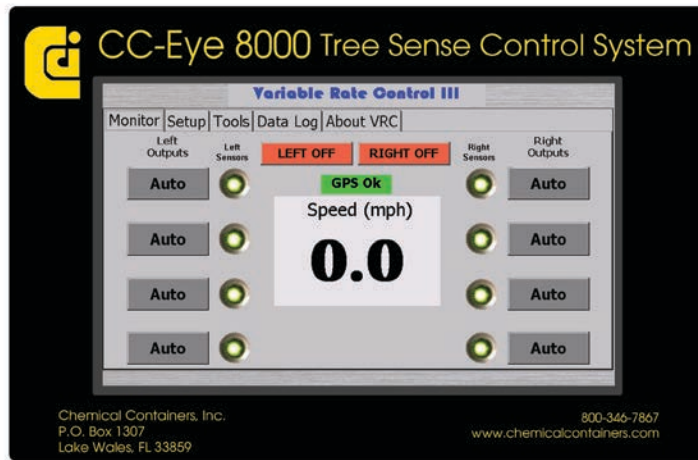

## Features:

- Touch Screen Programming- Easily programmable for first time users!
- Our Exclusive “Look Ahead Feature”
  - The CC-EYE 8000 Tree Sense Control System factors in the mechanical delay of the implement while constantly monitoring for changes in the speed of the implement using GPS. When the implement speed changes, the system automatically recalculates the “look ahead distance” to assure that the pre-set application buffer is achieved before and after the target.
- Application Target Buffers
  - Allows users to increase or decrease in one inch increments the distance that the application begins ahead of and continues past the targeted tree.
- Infrared Sensing Eyes can be mounted on implement or tractor.
  - Allows for Growers to use same CC- EYE 8000 Tree Sense Control System controller with multiple implements.
- Capable of storing multiple spray program settings
- Up to 8 zones on sprayers or spreaders
- Patented technology!



3 eyes per side system - installed on a BBI TruSpread



## Chemical Containers Commercial Spray Rigs:

- Open or all enclosed body styles.
- All welded unitized aluminum structure with aircraft grade aluminum bodies.
- PTO or Honda driven pumps for Tree and or Lawn spraying applications.
- Structural decking for maximum load capacity.
- Curbside operator controls.
- DOT - LED lighting and safety strobe lights.
- ROM aluminum locking roll-up doors.
- Custom interior shelving and dividers.
- High pressure jet agitation available.
- Stainless steel control manifolds.
- Epoxy primer coat with automotive final paint coat.
- Complete user's manual and Full 1 year warranty



For more information please visit:  
**[www.chemicalcontainers.com](http://www.chemicalcontainers.com)**





+	FT
+	FE
+	FE
+	FE
+	FE
+	FE

INJECTION PUMP  
SUCTION PORT

### Chemical Containers Custom Herbicide Spray Equipment

- All welded unitized aluminum structure with aircraft grade aluminum bodies.
- Poly nurse tanks w/baffles and agitation.
- Chemical injection systems available.
- Complete in-cab operation (Mid-Tech TASC 6300 available).
- Custom tool boxes with interior shelving.
- LED lighting and safety strobes.
- Adjustable road-side boom (removable for LH or RH spraying).
- Front bumper spray boom with curb and gutter sprayer.
- Remote EPA vacuum overhead fill valve
- Honda powered centrifugal pump.
- Electric rewind hose reel for manual applications.
- Complete user's manual and Full 1 year warranty





## Chemical Containers Custom Rail Sprayers

Complete line of herbicide sprayers specifically designed for railroad spraying.

- 2000 and 3000 gallon welded aluminum bodies
- 550 and 750 gal crossing sprayers
- Tee-Jet Aeros controller w/ mapping
- 50' from center of truck spray coverage
- Chemical storage
- Metered transfer of chemical to spray tank
- Injection systems





## Chemical Containers Custom Ag. Equipment

Complete line of agricultural sprayers including:

- Citrus sprayers
- Row crop sprayers
- Nursery sprayers
- Fertilizer spreaders
- Herbicide booms
- Bulk fertilizer tank farms
- Injection systems





## Turbo TeeJet® Wide Angle Flat Spray Tips



### Features:

- Tapered edge wide angle flat spray pattern for uniform coverage in broadcast spraying.
- Large, rounded internal passage to minimize clogging.
- Excellent resistance to corrosive solution.
- Superior wear characteristics.
- Large droplets for less drift 15-90 PSI (1-6 bar).
- Automatic spray alignment with 25612-\*<sup>-</sup>NYR Quick TeeJet cap and gasket.
- Unique internal configuration means substantially longer wear life.



## AI TeeJet® Air Induction Flat Spray Tips



### Features:

- Stainless steel insert produces a tapered edge flat spray pattern for uniform coverage in broadcast spraying
- Polymer insert holder and pre-orifice with VisiFlo color-coding.
- Large droplets for less drift.
- Available in eight capacities with a recommended pressure rating 30-115 PSI (2-8 bar) depending on the chemical, produces large air-filled drops through the use of a Venturi air aspirator
- Automatic spray alignment with 25598-\*<sup>-</sup>NYR Quick TeeJet cap and gasket.



## TeeJet® VisiFlo® Flat Spray Tips



### Features:

- Tapered edge flat spray pattern for uniform coverage in broadcast spraying.
- VisiFlo color-coded version available in stainless steel, ceramic and polymer in 80° or 110° spray angles in select sizes.
- Available in ceramic 80° capacities 01-02 and 110° capacities 01-015
- Standard version available in 15°, 25°, 40°, 50° and 65° spray angles in brass, stainless steel and hardened stainless steel.
- Automatic spray alignment with 25612-\*<sup>-</sup>NYR Quick TeeJet cap and gasket.
- Automatic spray alignment for sizes 10 through 20 with 25612-\*<sup>-</sup>NYR Quick TeeJet cap and gasket.



## FloodJet® Wide Angle Flat Spray Tips



## TeeJet® Off-Center Flat Spray Tips — Smaller Capacities

- TeeJet Off Center spray tips are commonly installed on double and single swivel nozzle bodies
- Because these bodies are adjustable for angular position, a wide spray swath is easily obtained

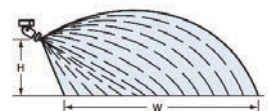



## **TXR ConeJet**® Hollow Cone Spray Tips

### Typical Applications:

Use for directed applications in air blast spraying for orchards and vineyards and other specialty crops. Also well suited for applications of insecticides, fungicides, defoliant and foliar fertilizers at pressures of 40 PSI (3 bar) and above.

### Features:

- Produces uniform, 80° hollow cone spray pattern ideal for airblast, directed and specialty applications.
- Flow rates are matched to serve as a direct replacement for commonly used non-TeeJet hollow cone spray tips.
- High quality ceramic orifice provides superior wear life, including high-pressure operation.
- Low profile acetal tip body provides minimal impact with foliage and excellent chemical resistance.
- Color coded holder based on tip flow rate allows for easy capacity identification.
- Snap-fit backup plate provides positive retention when handled in field, but allows for tool-free removal for easy cleaning.
- Best suited for use with TeeJet series 98450 brass rollover fittings.
- Compatible with TeeJet cap CP20230 for use on rollovers and threaded nozzle bodies, tighten to a maximum torque of: 100 in-lbs.
- Suggested spray range of 30-360 PSI (2-25 bar)
- Use 114396-1-NYR Quick TeeJet cap, gasket and ring

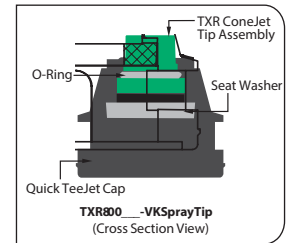

## **TeeJet** Disc-Core Type Hollow Cone Spray Tips



### Typical Assembly with Ceramic Disc and Core



\*Use CP20229-NY gasket when 4514-NY Nylon slotted strainer is not used.

**Hollow Cone Spray Pattern**  
Produced by Cores #13, 23, 25, 45 & 46



## **TeeJet** Specialty Fittings

### Typical Applications:

TeeJet rollovers are designed for use on air blast sprayers in orchard and vineyard spraying applications. These compact rollovers are available with or without diaphragm check valve, offer a choice of single- or double-outlet configurations, and are available with a variety on inlet connection sizes and thread types. Precision machined forged brass construction makes TeeJet rollovers both rugged and durable.

### Features:

- Maximum recommended pressure of 750 PSI
- Flow rate of 1.6 GPM with 10 PSI pressure drop
- Two shutoff positions at 90° from open
- Three open positions at vertical and +/- 15° from vertical with positive detent
- 11/16"-16 outlet thread accepts standard tip retaining caps.

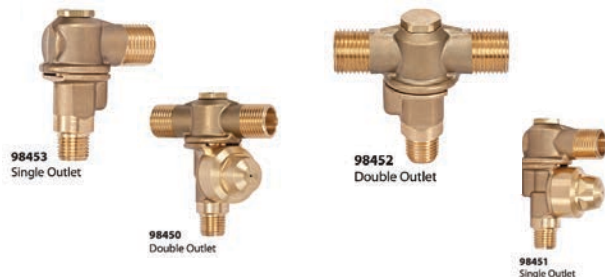



## Quick TeeJet® Caps

ColorCode

1	2	3	4	5	6	7	8	9	10	11	12	13
Black	White	Red	Blue	Green	Yellow	Brown	Orange	Gray	Violet <sup>1</sup>	Lt. Blue <sup>1</sup>	Telemagenta <sup>1</sup>	Lt. Green <sup>1</sup>

### Ordering Information

QUICK TEEJET CAPS	PART NUMBER		FOR USE WITH TEEJET SPRAY TIPS 300 PSI (20 bar) MAXIMUM PRESSURE
	QUICK TEEJET CAP ONLY	QUICK TEEJET CAP & SEAT GASKET SET	
	CP114440- <sup>*</sup> -CE	114441- <sup>*</sup> -CELR 114441- <sup>*</sup> -CELVI	<b>TeeJet® Flat Spray Tips</b> (Smaller Capacities) TP Standard -0067 to -08 DG TeeJet® XR -01 to -08 Turbo TeeJet® -01 to -08 Turbo TwinJet® OC TeeJet® AIXR TeeJet® -015 to -06
	CP25611-9-PP <sup>1</sup>	25612-9-PP <sup>1</sup>	
	CP25609- <sup>*</sup> -NY	25610- <sup>*</sup> -NYR	<b>TeeJet Flat Spray Tips</b> (Larger Capacities) TP Standard -10 to -20 XR -10 to -15
	CP114442- <sup>*</sup> -CE	114443- <sup>*</sup> -CELR 114443- <sup>*</sup> -CELVI	TJ60 TwinJet® AI TeeJet® and AIUB TeeJet® AI Turbo TwinJet® -02 to -06 Turbo TeeJet® Induction -015 to -06 DG TwinJet® S3 StreamJet AIXR TeeJet® -08 to -10
	CP114501- <sup>*</sup> -CE <sup>6</sup>	114502- <sup>*</sup> -CELR <sup>6</sup> 114502- <sup>*</sup> -CELVI <sup>6</sup>	AI Turbo TwinJet® -08 to -15 Turbo TeeJet® Induction -08 to -10 Turbo TeeJet® -10 to -12
	CP98578-1-NY <sup>2</sup>	98579-1-NYR <sup>2</sup>	AI3070
	CP25595- <sup>*</sup> -NY	25596- <sup>*</sup> -NYR	<b>TeeJet Flat Spray Tips</b> (Smaller Capacities) Tips can be positioned in choice of two spray plane directions—parallel or perpendicular to wings of Quick TeeJet cap.
	CP25599- <sup>*</sup> -NY	25600- <sup>*</sup> -NYR	Turbo FloodJet® TK-VP FloodJet® TK-VS FloodJet® Locating Nib
	CP114444- <sup>*</sup> -CE	114445- <sup>*</sup> -CELR 114445- <sup>*</sup> -CELVI	TK FloodJet® FL FullJet® TX/TXA ConeJet® TG Full Cone Hose Shank AITXA ConeJet
	CP25607-9-PP <sup>1</sup>	25608-9-PP <sup>1</sup>	
	CP114444- <sup>*</sup> -CE	—	Disc Core Seal CP18999-EPR Disc-Core (Insert Core into Seal)
	CP26277-1-NY <sup>2</sup>	26278-1-NYR <sup>2</sup>	Ceramic Disc-Core D-Disc Core TXB ConeJet® AITXB ConeJet®
	CP114395-1-NYB <sup>3</sup>	114396-1-NYR <sup>3</sup>	114396-1-NYR includes gasket and O-Ring (CP7717-M10.5x1.5-VI) TXR ConeJet®

\*Specify color code (see chart). <sup>1</sup>These caps only available in gray and rated to 150 psi (10 bar). <sup>2</sup>These caps only available in black.

<sup>3</sup> Color available in CP114440, CP114442 and CP114444 caps. <sup>4</sup> Color available in CP114440, CP114442 and CP114501 caps.

<sup>5</sup> Color available in CP114501 cap. <sup>6</sup> This cap offered in Black, White, Light Green, Light Blue and Telemagenta only.

### Quick TeeJet Cap

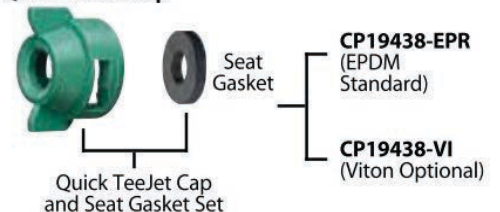

## Quick TeeJet® Adapters and Accessories

QJT8360-NYB,  
QJP19011-NYB,  
QJ8360-NYB

- Retrofits to a Quick TeeJet system.
- Features ChemSaver® no-drip shutoff. Requires 10 PSI (0.7 bar) at the nozzle to open check valve.
- Standard diaphragm of EPDM with optional Viton® available upon request.
- Maximum operating pressure of 300 PSI (20 bar).
- Flow rate: 2.25 GPM (8.5 l/min) at 5 PSI (0.34 bar) pressure drop, 3.18 GPM (12.0 l/min) at 10 PSI (0.69 bar) pressure drop.



QJ8360-NYB



QJT8360-NYB  
QJP19011-NYB

QJ8355-NYB

- Allows use of Quick TeeJet system with 1/8" and 1/4" NPT female connections.
- Side mounting provides protection of the nozzle body.
- Features ChemSaver no-drip shutoff. Requires 10 PSI (0.7 bar) at the nozzle to open check valve.
- Standard diaphragm of EPDM with optional Viton available upon request.
- Maximum operating pressure of 300 PSI (20 bar).
- Flow rate: 2.25 GPM (8.5 l/min) at 5 PSI (0.34 bar) pressure drop, 3.18 GPM (12.0 l/min) at 10 PSI (0.69 bar) pressure drop.



50854-NYB

- For use with Quick TeeJet nozzle bodies to extend body length by 1 inch (25 mm).
- Used to eliminate interference of spray pattern with sprayer boom structure or shields, particularly with twin pattern or fertilizer spray tips.
- Nylon body construction with EPDM gasket.
- Maximum operating pressure of 300 PSI (20 bar).



QJL1/4T-NYB & QJT-NYB

- QJL1/4T-NYB allows use of Quick TeeJet system with 1/4" NPT and BSPT male connections.
- QJT-NYB permits use of Quick TeeJet system with standard 1/4"-16 TeeJet thread.
- Maximum operating pressure of 300 PSI (20 bar).



QJ90-1-NYR

- Fits standard Quick TeeJet bodies.
- Nylon body construction for strength and durability, with EPDM gasket (Viton® optional).
- Outlet can be fitted with Quick TeeJet caps and TeeJet spray tips.
- One piece, 90° elbow is ideal for installation of TK-VS FloodJet® and TF-VS or TF-VP Turbo FloodJet nozzles on single or multiple outlet nozzle bodies. Proper orientation of spray tip enhances spray distribution quality.
- Adapter outlet accepts standard tip strainers.
- Maximum operating pressure of 300 PSI (20 bar).



QJL1/4TT-NYB

- Allows use of Quick TeeJet system with 1/4" NPT and BSPT female connections.
- Maximum operating pressure of 300 PSI (20 bar).



QJ90-2-NYR

- Fits standard Quick TeeJet bodies.
- Made of Nylon with CP19438-EPR gasket (included).
- Use with Quick TeeJet cap and gasket for automatic alignment when using flat fan spray tips.
- 90° included angle between outlets. When used with standard flat fan tips produces a twin type spray pattern for improved coverage and canopy penetration.
- Maximum operating pressure of 300 PSI (20 bar).



55240-CELR

- Converts Hardi® snap-fit nozzle body connection to Quick TeeJet connection for easy installation of TeeJet tips. Especially useful for AIC, XRC and SJ7 tips.
- Acetal construction with EPDM gasket for durability and chemical resistance.
- Accepts standard tip strainers.
- Maximum operating pressure of 150 PSI (10 bar).



## TeeJet® ChemSaver® Diaphragm Check Valves

In this type of nozzle body, the diaphragm check valve is an integral part of the nozzle assembly. This design eliminates the pressure drop associated with ball-type check valves. The spring-backed diaphragm ensures dependable closure. Originally developed for use in aerial spraying, nozzle bodies of this design are now widely used wherever drip-free shutoff is required. For maximum operating pressures of 125 PSI (9 bar).

Typical Assembly

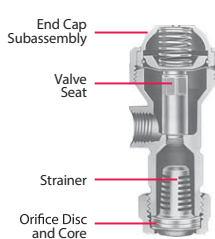

8355

Made of Nylon with Nylon/polypropylene end cap assembly. Check valve opens at 10 PSI (0.7 bar) pressure. Choice of 1/8" or 1/4" NPT (F) inlet connections. Flow rate for 1/8" is 3 GPM at 5 PSI pressure drop (11.4 l/min at 0.34 bar). Flow rate for 1/4" is 3.9 GPM at 5 PSI pressure drop (15 l/min at 0.34 bar). Overall length 2 3/4" (70 mm). Weight: 1 1/2 ounces (43 g).



12328-NYB

Made of Nylon with Celcon® bonnet. Check valve opens at 7 PSI (0.5 bar) pressure. (M) inlet connection and (F) outlet connections. Choice of 1/2" and 3/4" NPT sizes. Flow rate for 1/2" is 12 GPM at 5 PSI pressure drop (45 l/min at 0.34 bar). Flow rate for 3/4" is 16 GPM at 5 PSI pressure drop (61 l/min at 0.34 bar). Overall length 3" (76 mm). Weight: 9 ounces (0.26 kg).



### ChemSaver® Diaphragm Check Valve Nozzle Bodies

Similar in design and performance to the TeeJet® Diaphragm Check Valve nozzle bodies, but with pipe thread outlet connections for spray nozzles instead of TeeJet caps and spray tips. For maximum operating pressures of 125 PSI (9 bar).



6135A

Made of brass. Check valve opens at 7 PSI (0.5 bar) pressure. Choice of 1/4" and 3/8" NPT (F) inlet connections. Flow rate of 4.5 GPM at 5 PSI pressure drop (17 l/min at 0.34 bar). Overall length 2 3/8" (67 mm). Weight: 4 1/2 ounces (128 g).



4664B

Made in choice of brass or aluminum with replaceable stainless steel valve seat. Check valve opens at 7 PSI (0.5 bar) pressure. 1/8" NPT (F) inlet connection. Flow rate of 2.0 GPM at 5 PSI pressure drop (7.5 l/min at 0.34 bar). Overall length 2 5/8" (59 mm). Weights: brass 3 ounces (85 g), aluminum 1 ounce (28 g).



6140A

Made of brass. Check valve opens at 7 PSI (0.5 bar) pressure. Choice of 1/4" and 3/8" NPT (F) inlet connections. Outlet connection has dual 1/2" NPT external (M) thread and 3/8" NPT internal (F) thread. Flow rate of 4.5 GPM at 5 PSI pressure drop (17 l/min at 0.34 bar). Overall length 2 3/8" (61 mm). Weight: 2 1/2 ounces (71 g).



8360

Made of Nylon with Nylon/polypropylene end cap assembly. Check valve opens at 10 PSI (0.7 bar) pressure. 1/4" NPT (M) inlet connection. Flow rate of 2.25 GPM at 5 PSI pressure drop (8.5 l/min at 0.34 bar). Overall length 2" (51 mm). Weight: 1 ounce (28 g).



4666B

Made in brass with replaceable stainless steel valve seat. 1/8" NPT (F) inlet and outlet connections. Flow rate of 2.0 GPM at 5 PSI pressure drop (7.5 l/min at 0.34 bar). Overall length 1 5/8" (49 mm). Check valve opens at 7 PSI (0.5 bar) pressure. Weight: 2 1/2 ounces (71 g).



B10742A

Made in choice of brass or aluminum. Check valve opens at 7 PSI (0.5 bar) pressure. 1/4" NPT (M) inlet and (F) outlet connections. Overall length 1 7/8" (37 mm). Flow rate of 2.25 GPM at 5 PSI pressure drop (8.5 l/min at 0.34 bar). Weights: brass 2 1/2 ounces (71 g), aluminum 2 ounces (57 g).

# CHEMICAL CONTAINERS, INC. - CUSTOM EQUIPMENT

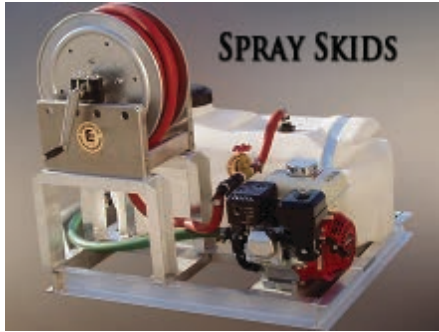

## LAKE WALES

413 ABC Rd.  
Lake Wales, Fl. 33859  
(863) 638-1407

## ZOLFO SPRINGS

3322 Hwy 17 S  
Zolfo Springs, Fl. 33890  
(863) 474-3051

## CLEWISTON

742 E Sagamore Ave.  
Clewiston, Fl. 33440  
(863) 301-3520

## FORT PIERCE

15897 Orange Ave.  
Ft. Pierce, Fl. 34945  
(772) 801-5326

## PLANT CITY

601 Hitchcock St.  
Suite 103  
Plant City, Fl. 33563  
(813) 752-1982

## ARCADIA

440 N. Brevard Ave.  
Arcadia, Fl. 34266  
(863) 491-0165

## SEBRING

6402 US Hwy 27 South  
Sebring, Fl. 33876  
(863) 314-6647

## LYONS

699 South State St.  
Lyons, Ga. 30436  
(912) 388-2154

**SPECIALISTS** <sup>IN</sup> LIQUID  
HANDLING PRODUCTS